



V Series Filter/Separators

APPLICATIONS

- Diesel Fuels
- Kerosene
- Gasoline

INSTALLATIONS

- Airports
- Loading Racks
- Refineries
- Gas Turbines
- Terminals

STANDARD DESIGN FEATURES

- Threaded Base Coalescer Elements
- Pleated Paper Separator Elements
- 150 psi ASME Code Construction
- RF Flanged Connections
- Swing Bolt Closure with O-ring Seal
- Epoxy-Coated Interior, Primed Exterior

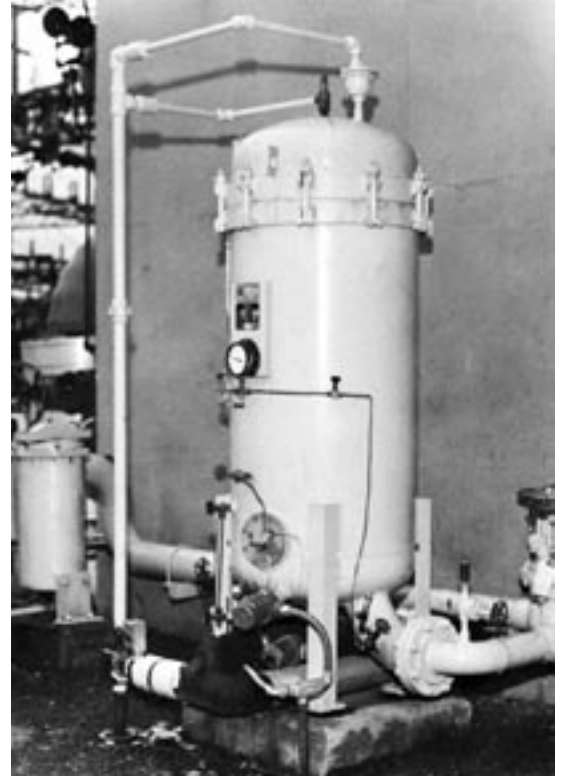

Pleated paper second stage cartridges are standard in V series Filter/Separators for Diesel Grade Fuels and also for Jet Fuel installations where this type of cartridge is specified.

OPTIONAL ACCESSORIES

The accessory items marked with an (R) are recommended for safe, effective operation of all installations.

Automatic Air Vent (R)

Pressure Relief Valve (R)

Differential Pressure Gauge (R)

Manual Drain Valve (R)

Water Slug Valve (R)

Water Interface Control (R)

Sampling Probes (R)

Sump Heater

Sight Glass

FLOW SIZING

Vessel Model No.	Flow Rates (USGPM) ⁽¹⁾			Coalescer Element Option			Separator Element	
	Diesel	Kerosene	Gasoline	Qty.	Diesel	"83" Series ⁽²⁾	Qty.	Model No.
V-2222	135	200	260	4	I-6224TB	I-62283TB	6	SO-611PLF3
V-2233	200	300	390	4	I-6334TB	I-63383TB	3	SO-629PLF3
V-2833	300	450	520	6	I-6334TB	I-63383TB	5	SO-629PLF3
V-2844	400	600	780	6	I-6444TB	I-64483TB	5	SO-633PLBZ
V-3638	600	950	1230	11	I-6384TB	I-63883TB	9	SO-629PLF3
V-3644	720	1100	1430	11	I-6444TB	I-64483TB	9	SO-633PLBZ
V-3656	900	1400	1820	11	I-6564TB	I-65683TB	9	SO-644PLBZ
V-4244	1000	1500	1939	15	I-6444TB	I-64483TB	12	SO-633PLBZ
V-4256	1250	1900	2470	15	I-6564TB	I-65683TB	12	SO-644PLBZ

NOTES: (1) Based on minimum Interfacial Tension of 36 dynes per centimeter
 (2) Recommended for kerosene and gasoline service

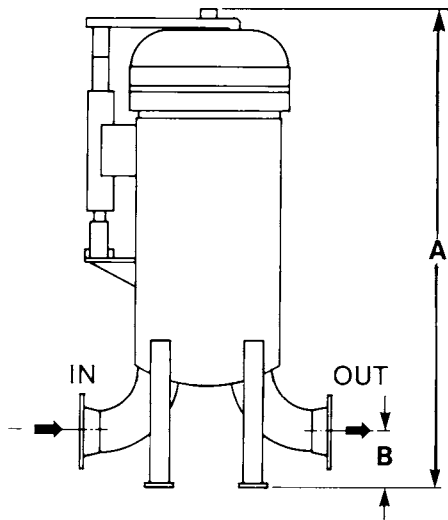

DIMENSIONS

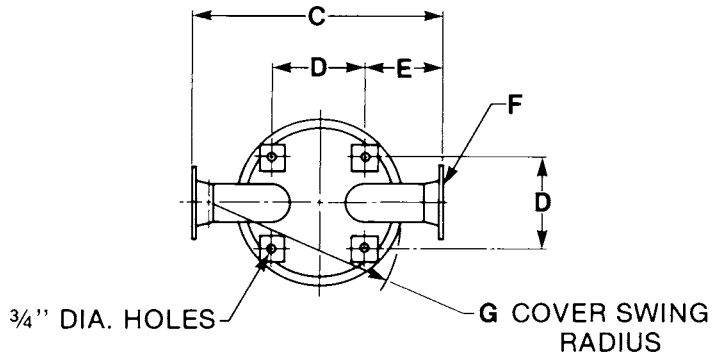

Obtain Certified Hole Pattern before Pouring Slabs.

Vessel Model No.	Cover Style	Dimensions (Inches)*							Weight w/ Skid lbs.	Volume U.S. Gal.
		A	B	C	D	E	F	G		
V-2222	Flat	62	8	27 ¹ / ₈	15 ¹ / ₂	6 ¹ / ₄	4	30	1110	64
V-2233	Flat	68	8	27 ¹ / ₈	15 ¹ / ₂	6 ¹ / ₄	4	30	1130	72
V-2833	Dome	84	8	40	18	11	6	36	1650	170
V-2844	Dome	89 ³ / ₈	8	40	18	12 ⁵ / ₈	6	36	1690	185
V-3638	Dome	91 ¹ / ₂	8	63 ¹ / ₄	23 ¹ / ₂	19 ⁷ / ₈	6	44	2080	280
V-3644	Dome	93 ³ / ₄	9	52 ¹ / ₈	23 ¹ / ₂	14 ⁵ / ₁₆	8	44	2150	305
V-3656	Dome	105	9	52 ¹ / ₈	23 ¹ / ₂	14 ⁵ / ₁₆	8	44	2300	355
V-4244	Dome	101 ³ / ₈	9	55 ¹ / ₈	28	13 ¹ / ₂	8	50	3350	450
V-4256	Dome	113 ³ / ₈	9	55 ¹ / ₈	28	15	8	50	3500	520

*Dimensions are shown for estimation purposes. For exact dimension detail, obtain certified copy of Vessel Drawing.

Velcon products are sold and serviced by a world-wide representative network. To order, contact Headquarters or your **LOCAL REPRESENTATIVE**:

COMPANY HEADQUARTERS:
 Velcon Filters, Inc.
 1210 Garden of the Gods Road
 Colorado Springs, CO 80907-3410
 Phone: 1.800.531.0180 / 1.719.531.5855
 Fax: 719.531.5690
 e-mail: vfsales@velcon.com
 www.velcon.com

MANUFACTURING PLANTS LOCATED AT:
 Colorado Springs, Colorado
 Sylacauga, Alabama

OVERSEAS AFFILIATES:
 Frankfurt/M., Germany & Singapore

**Liquid Filtration
 and Separation
 Specialists**