



Filter/Separators

V Series

APPLICATIONS

- Diesel Fuels
- Biodiesel
- Kerosene
- Gasoline

INSTALLATIONS

- Airports
- Loading Racks
- Refineries
- Gas Turbines
- Terminals

STANDARD DESIGN FEATURES

- Threaded Base Coalescer Cartridges
- Pleated Paper Separator Cartridges
- 150 psi ASME Code Construction
- RF Flanged Connections
- Swing Bolt Closure with O-ring Seal
- Epoxy-Coated Interior, Primed Exterior

Pleated paper second stage cartridges are standard in V Series Filter/Separators for Diesel Grade Fuels and also for Jet Fuel installations where this type of cartridge is specified.

OPTIONAL ACCESSORIES

The accessory items marked with an (R) are recommended for safe, effective operation of all installations.

Automatic Air Vent (R)

Pressure Relief Valve (R)

Differential Pressure Gauge (R)

Manual Drain Valve (R)

Water Slug Valve (R)

Water Interface Control (R)

Sampling Probes (R)

Sump Heater

Sight Glass



FLOW SIZING

Vessel Model No.	Flow Rates (USGPM) ⁽¹⁾			Coalescer Cartridge Option			Separator Cartridge	
	Diesel	Kerosene	Gasoline	Qty.	Diesel	"83" Series ⁽²⁾	Qty.	Model No.
V2222	135	200	260	4	I-6224TB	I-62283TB	3	SO-622PLBZ
V2233	200	300	390	4	I-6334TB	I-63383TB	3	SO-629PLF3
V2833	300	450	520	6	I-6334TB	I-63383TB	5	SO-629PLF3
V2844	400	600	780	6	I-6444TB	I-64483TB	5	SO-633PLFZ
V3638	600	950	1230	11	I-6384TB	I-63883TB	9	SO-629PLF3
V3644	720	1100	1430	11	I-6444TB	I-64483TB	9	SO-633PLFZ
V3656	900	1400	1820	11	I-6564TB	I-65683TB	9	SO-644PLFZ
V4244	1000	1500	1939	15	I-6444TB	I-64483TB	12	SO-633PLFZ
V4256	1250	1900	2470	15	I-6564TB	I-65683TB	12	SO-644PLFZ

NOTES: (1) Based on minimum Interfacial Tension of 36 dynes per centimeter
 (2) Recommended for kerosene and gasoline service

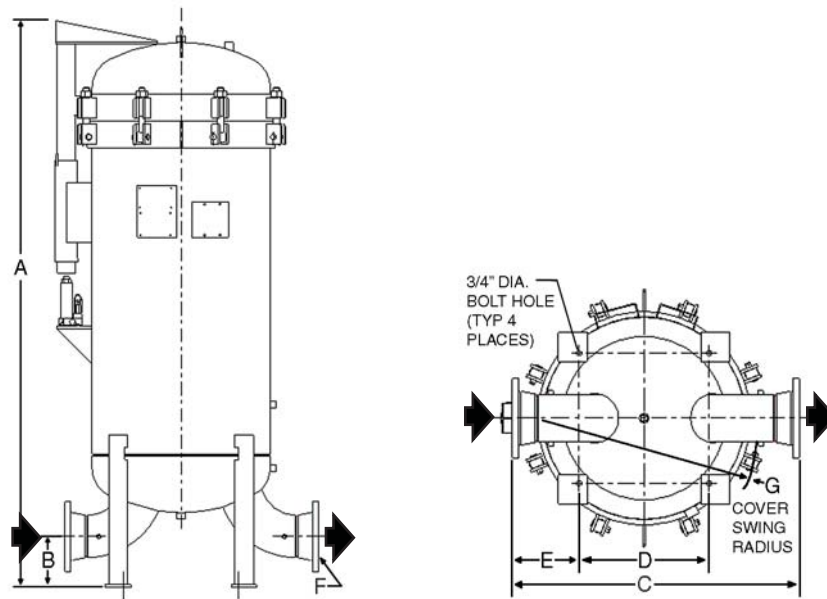

VESSEL DIMENSIONS

Vessel Model No.	Cover Style	Dimensions (Inches)*							Weight w/ Skid (lbs)	Volume (US gal)
		A	B	C	D	E	F	G		
V2222	Flat	62	8	27 1/8	15 1/2	6 1/4	4	30	1110	64
V2233	Flat	69	8	27 1/8	15 1/2	6 1/4	4	30	1130	72
V2833	Dome	83	8	40	18	12 5/8	6	35	1650	170
V2844	Dome	89	8	40	18	12 5/8	6	35	1690	185
V3638	Dome	91 9/16	8	63 1/4	23	20 1/8	6	44	2080	280
V3644	Dome	96 3/8	9	52 1/8	23	14 5/8	8	44	2150	305
V3656	Dome	109 11/16	9	52 1/8	23	14 5/8	8	44	2300	355
V4244	Dome	103 3/8	9	55 5/16	28	15	8	50	3350	450
V4256	Dome	115 3/8	9	55 5/16	28	15	8	50	3500	520

*Dimensions are shown for estimating purposes only. For exact dimensional detail, obtain certified copy of vessel drawing.



Velcon products are sold and serviced by a world-wide representative network. To order, contact Headquarters or your LOCAL REPRESENTATIVE:

COMPANY HEADQUARTERS:
 Velcon Filters, Inc.
 1210 Garden of the Gods Road
 Colorado Springs, CO 80907-3410
 Phone: 1.800.531.0180 / 1.719.531.5855
 Fax: 719.531.5690
 e-mail: vfsales@velcon.com
 www.velcon.com

MANUFACTURING PLANTS LOCATED AT:
 Colorado Springs, Colorado
 Sylacauga, Alabama
 Henryetta, Oklahoma

OVERSEAS AFFILIATES:
 Frankfurt/M., Germany & Singapore

**Liquid Filtration
 and Separation
 Specialists**

Due to Velcon Filters' continuing product improvement, drawings, specifications and pictures are subject to change without notice.