

- **Compact**
- **Flexible Filtration**
- **Multipurpose Design**
- **Simplified Maintenance**

DESCRIPTION

The compact Vel-Max[®] Filter Vessel is suitable for flowrates up to 204 USGPM with micronics cartridges, up to 198 USGPM as a filter/separator, and up to 150 USGPM with CDF[®] monitor cartridges. The Vel-Max[®] can be used on mobile refueling equipment, fueling cabinets and for fixed fueling installations. Vel-Max[®] is designed for easy maintenance and easy conversion to a prefilter, filter/separator, or monitor.

APPLICATIONS

- Jet Fuel
- Avgas
- Motor Gasoline
- Diesel Fuel
- Kerosene
- Turbine Lube Oil
- Insulating Oil
- Biodiesel Blends

STANDARD FEATURES

- Carbon steel construction
- 250 psi design pressure
- Epoxy powder coated interior & exterior
- 2" NPT female inlet/outlet
- 1/2" NPT drain connection
- 3/4" NPT vent and relief connection
- 1/2" NPT sight glass connections
- 1" NPT water probe connection
- 1/8" NPT differential pressure gauge connections
- Lid Gasket: G-2052 (Buna N)



Vel-Max[®] Filter Vessel, VX-2, showing optional leg assembly, differential pressure gauge, sight glass assembly, and air eliminator.

OPTIONAL FEATURES

- Air eliminator
- Drain valve
- Pressure relief valve
- Water probe
- Sight gauge
- Leg assembly with adjustable height
- ASME Code Stamp
- CE Mark
- Differential pressure gauge assembly
- Lid Gasket: G-2052V (Viton)

Vel-Max® Filter Vessel Configurations/Applications

Filter/Separator Configuration

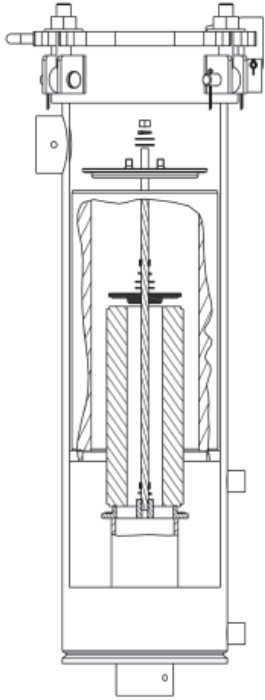

Vel-Max® Series for liquid/liquid separation uses a 2-stage coalescer separator cartridge combination to remove free and emulsified water from a liquid product stream. The first stage coalescing cartridge provides filtration as well as coalescing of free and emulsified water. The second stage separator is a hydrophobic barrier designed to repel the coalesced water droplets. The water droplets will fall and collect in the sump for removal through the manual drain.

6" or 6.25" OD x 2.625" ID Configuration

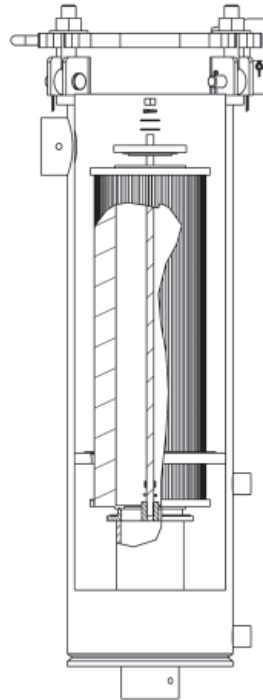

Vel-Max® Series for 6" or 6.25" OD x 2.625" ID cartridges can be used in several ways. To remove solid contaminants from a flow stream, use the vessel with a pleated media filter. When used with **Aquacon**® cartridges the Vel-Max® will remove solids and free water by absorption from a fuel or industrial oil flow stream. Using Vel-Max® with clay cartridges will remove surfactants, color and other impurities by adsorption from a fuel or industrial oil system.

6" OD x 3.5" ID Configuration

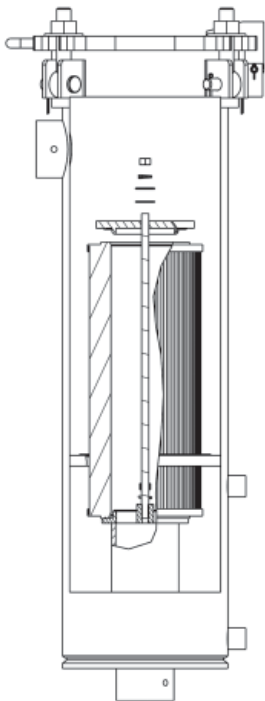

Vel-Max® Series with 6" OD x 3.5" ID cartridges can be used in two ways. To remove solid contaminants from a flow stream, use the vessel with a pleated media filter. When used with **Aquacon**® cartridges* the Vel-Max® will remove solid contaminants and free water by absorption from a jet fuel or aviation gasoline flow stream.

CDF® Monitor Configuration

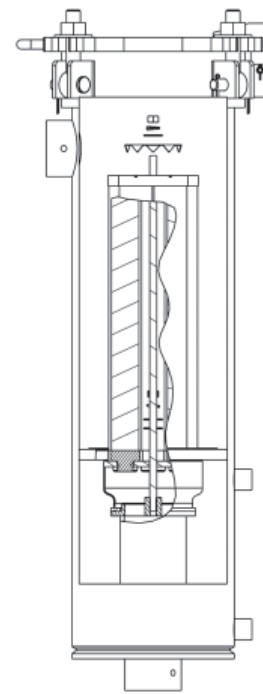

Vel-Max® Series can be adapted to use 2" diameter CDF® type monitor cartridges* for removing solid contaminants and free water by absorption from jet fuel or aviation gasoline flow streams.

***CAUTION: Do not use Aquacon® or CDF® water absorbing monitor cartridges in pre-mixed jet fuel containing anti-icing additives (DiEGME, FIZZY®, Prist®, FSII)**

Vel-Max® Filter Vessel Specifications

DIMENSIONS

Model	Height		Cover Width		Cover Length		Dry Weight	
	Inches	mm	Inches	mm	Inches	mm	lbs	kgs
VX-1	36	914	13 7/16	341	11 5/8	295	110	50
VX-2	51	1295	13 7/16	341	11 5/8	295	125	57
VX-3	66	1676	13 7/16	341	11 5/8	295	150	68

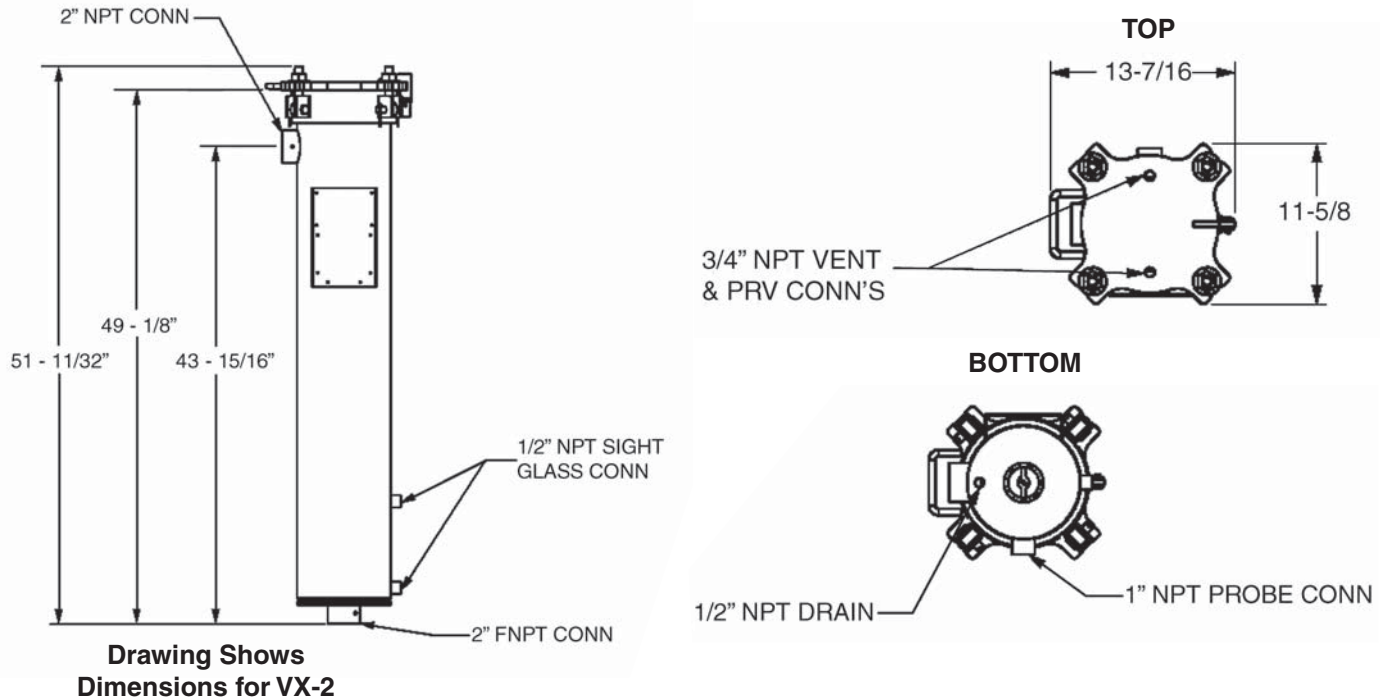

Dimensions shown are for estimating purposes only.
For exact dimensional detail, obtain certified copy of vessel drawing.

FLOW RATES

CONFIGURATION	APPLICATIONS	VX-1	VX-2	VX-3
FILTER / SEPARATOR	TURBINE LUBE OIL (ISO 32, 100°F)	3.5 USGPM	7.5 USGPM	11.5 USGPM
	INSULATING OIL (80°F)	6.1 USGPM	13.5 USGPM	20.0 USGPM
	DIESEL FUEL	25 USGPM	50 USGPM	75 USGPM
	GASOLINE / AVIATION GASOLINE	66 USGPM	132 USGPM	198 USGPM
	JET FUEL / KEROSENE	50 USGPM	100 USGPM	150 USGPM
MICRONIC CARTRIDGES 6" OD x 3.5" ID	OILS	CONTACT FACTORY		
	DIESEL FUEL	50 USGPM	100 USGPM	150 USGPM
	GASOLINE / AVIATION GASOLINE	68 USGPM	136 USGPM	204 USGPM
	JET FUEL / KEROSENE	66 USGPM	132 USGPM	198 USGPM
AVIATION Aquacon ® CARTRIDGES 6" OD x 3.5" ID	JET FUEL / KEROSENE	58 USGPM	115 USGPM	176 USGPM
INDUSTRIAL MICRONIC & Aquacon ® CARTRIDGES 6" or 6.25" OD x 2.625" ID	OILS	CONTACT FACTORY		
	DIESEL / GASOLINE / AV GAS / JET FUEL / KEROSENE	50 USGPM	100 USGPM	150 USGPM
CLAY CARTRIDGES (LA-61801B)	INSULATING OIL	1 USGPM	N/A	2 USGPM
	JET FUEL / KEROSENE / GASOLINE	7.5 USGPM		15 USGPM
CDF® MONITOR CARTRIDGES	JET FUEL / KEROSENE / GASOLINE	75 USGPM	150 USGPM	N/A

Vel-Max® Cartridge Selection Table

CARTRIDGES

FILTER/SEPARATOR CONFIGURATION				
FIRST STAGE COALESCERS FOR:	MICRON RATING	VX-1	VX-2	VX-3
DIESEL FUEL	25	O-8150	O-8300	O-8440
	3	O-8154	O-8304	O-8444
DIESEL FUEL / GASOLINE	2	O-8156	O-8306	O-8446
JET FUEL / KEROSENE / DIESEL FUEL / TURBINE LUBE OIL / INSULATING OIL	0.5	O-81588	O-83088	O-84488
SECOND STAGE SEPARATORS FOR:	TYPE	VX-1	VX-2	VX-3
DIESEL	PAPER	SO-415PL	SO-430PL	SO-444PL
JET / KERO / GAS / OILS	TCS	SO-415VX5	SO-430VX5	SO-444C
6" OD X 3.5" ID CONFIGURATION	TYPE	VX-1	VX-2	VX-3
MICRONIC CARTRIDGES	PLEATED PAPER	FO-614PLFxx	FO-614PLFxx (STACK OF 2)	FO-614PLFxx (STACK OF 3)
			FO-629PLFxx	FO-644PLFxx
	FIBERGLASS DEPTH	FO-614FGxx	FO-614FGxx (STACK OF 2)	FO-614FGxx (STACK OF 3)
			FO-629FGxx	FO-644FGxx
AVIATION <i>Aquacon</i> ® CARTRIDGES*		ACO-61401L	ACO-61401L (STACK OF 2)	ACO-61405 (STACK OF 3)
			ACO-62901L	ACO-61401L (STACK OF 3)
INDUSTRIAL <i>Aquacon</i> ® CARTRIDGES			AC-61405	A(C/D)-614xx (STACK OF 2)
			AD-61410	A(C/D)-614xx (STACK OF 3)
			AD-61425	AC-62905
AC-64405				
6" OR 6.25" OD X 2.625" ID CONFIGURATION		VX-1	VX-2	VX-3
MICRONIC CARTRIDGES	PLEATED PAPER (FO) & PLEATED SYNTHETIC (FOS)	FO-718PLxx	N/A	(FO/FOS)-718xx (STACK OF 2)
		FOS-618PLxx		FO-736PLxx
		FOS-718PLxx		FOS-636PLxx
	FIBERGLASS DEPTH	FO-618FGAxx		FO-618FGAxx (STACK OF 2)
		FO-636FGAxx		
INDUSTRIAL <i>Aquacon</i> ® CARTRIDGES		AC-718xx	AC-718xx (STACK OF 2)	
			AC-736xx	
CLAY (FULLER'S EARTH) CARTRIDGES		LA-61801B	LA-61801B (STACK OF 2)	
CDF® MONITOR CONFIGURATION		VX-1	VX-2	VX-3
CDF® CARTRIDGES*		CDF-215N	CDF-230N	N/A

The suffix "xx" on the part number of cartridges denotes the micron rating of the cartridge.
Contact Velcon Filters, Inc. for available micron ratings.

HARDWARE KITS

CONFIGURATION	VX-1	VX-2	VX-3
FILTER / SEPARATOR (COALESCER + SEPARATOR)	VX1-FSKIT	VX2-FSKIT	VX3-FSKIT
6" OD X 3.5" ID CARTRIDGE(S)	VX1-AVKIT	VX2-AVKIT	VX3-AVKIT
6" OR 6.25" OD X 2.625" ID CARTRIDGE(S)	VX1-INKIT	N/A	VX3-INKIT
CDF® MONITOR CARTRIDGES	VX1-CDKIT	VX2-CDKIT	N/A

***CAUTION: Do not use *Aquacon*® or CDF® water absorbing monitor cartridges in pre-mixed jet fuel containing anti-icing additives (DiEGME, FIZZY®, Prist®, FSII)**



Velcon products are sold and serviced by a world-wide representative network. To order, contact Headquarters or your LOCAL REPRESENTATIVE:

COMPANY HEADQUARTERS:
 Velcon Filters, Inc.
 1210 Garden of the Gods Road
 Colorado Springs, CO 80907-3410
 Phone: 1.800.531.0180 / 1.719.531.5855
 Fax: 719.531.5690
 e-mail: vfsales@velcon.com
 www.velcon.com

MANUFACTURING PLANTS LOCATED AT:
 Colorado Springs, Colorado
 Sylacauga, Alabama
 Henryetta, Oklahoma

OVERSEAS AFFILIATES:
 Germany, Spain, Canada & Singapore

**Liquid Filtration
and Separation
Specialists**