



Portable Filter/ Separator Vessels

AVV Series



AVV1320C115

AVV1620C115

AVV2820C225

DESCRIPTION

Velcon's AVV Series portable filter/separator vessels are designed to remove water and solids from jet fuel, military fuels, and diesel fuel. The units can be deployed rapidly in the field to remote sites to ensure clean dry fuel. The vessels are built and qualified to ATPD 2320A for flow rates up to 350 USGPM and the cartridges have been tested and qualified to MIL-PRF-52308J.

APPLICATIONS

- Jet fuel
- Military fuels with anti-icing additive
- Diesel fuel

FEATURES

- Lightweight aluminum construction
- Vessel with transport frame can be lifted by 2-4 people according to lifting instructions
- Can be airlifted to site
- Supplied with:
 - a. Quick release cam-type fittings
 - b. Grounding rods
 - c. Protective paint finish to MIL-DTL-64159
 - d. Sight glass
 - e. Differential pressure gauge
- Optional Fuel Sampling Kit available

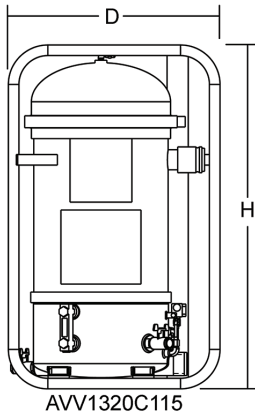

AVV1320C115

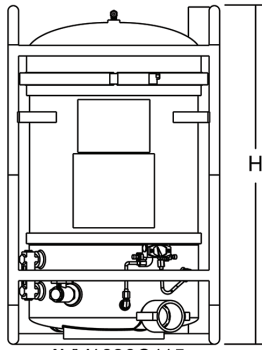

AVV1620C115

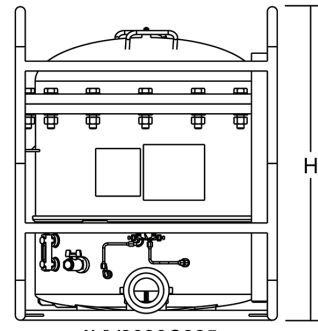

AVV2820C225

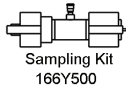
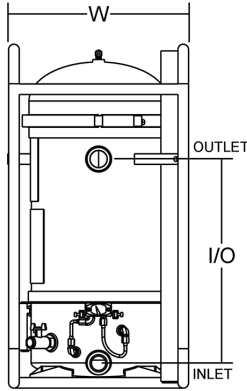

Sampling Kit
166Y500

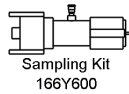
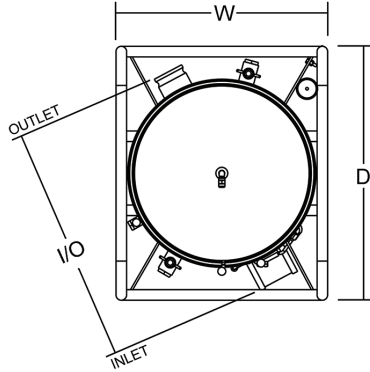

Sampling Kit
166Y600

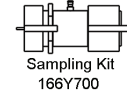
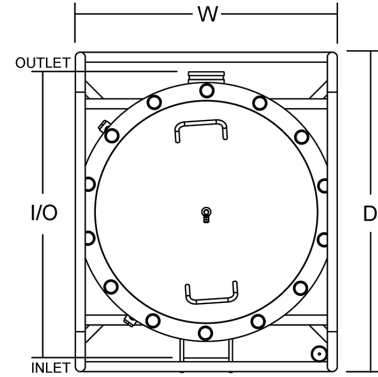

Sampling Kit
166Y700

Vessel Model Number	Dimensions in Inches				Dry Weight (lbs)	Volume (gal)	Optional Sampling Kit	
	Height (H)	Width (W)	Depth (D)	Inlet to Outlet (I/O)			Kit Model Number	Pipe Size/ Length
AVV1320C115	32.5	17	20	19.3	66	16	166Y500	1.5" NPT / 9"
AVV1620C115	32	20	24	22.25	88	22	166Y600	2" NPT / 9"
AVV2820C225	39.5	33	40.25	36	366	79	166Y700	4" NPT / 11"

Vessel Model Number	Qty. Coalescer I-420MM*	Qty. Separator SI-522*	Flow Rate (USGPM)		Rated Operating Pressure (psi)	Max Test Pressure (psi)
			Jet	Diesel		
AVV1320C115	3	3	50	25	77	115
AVV1620C115	5	5	100	50	77	115
AVV2820C225	18	18	350	175	150	225

*Please refer to data sheets #1915 for coalescer information and #1943 for separator information
Please note: The initial set of cartridges is included with the vessel. Consult instructions for changeout information.



Velcon products are sold and serviced by a world-wide representative network. To order, contact Headquarters or your LOCAL REPRESENTATIVE:

COMPANY HEADQUARTERS:
Velcon Filters, LLC
1210 Garden of the Gods Road
Colorado Springs, CO 80907-3410
Phone: 1.800.531.0180 / 1.719.531.5855
Fax: 719.531.5690
e-mail: vfsales@velcon.com
www.velcon.com

MANUFACTURING PLANTS LOCATED AT:
Colorado Springs, Colorado
Sylacauga, Alabama
Henryetta, Oklahoma

OFFICES AND AFFILIATES IN:
Canada, Germany, Singapore, & Spain



**Liquid Filtration
and Separation
Specialists**