



Horizontal Filter/Separators

HV and HVS Series
API/EI 1581 5th Edition Qualified

Compact Side and End Opening Horizontal Filter/Separator Vessels for Mobile Fueling Equipment

Designed Specifically for Hydrant Carts and Refuelers

FEATURES

- **Reduced Weight** is vital in the manufacture of refuelers and hydrant carts. Velcon Filter/Separators drastically reduce the weight of the vessel.
- **Reduced Size** is another important factor in designing refuelers and hydrant carts. Velcon Filter/Separators reduce the size of the vessel by up to 50%.
- **Easier Maintenance.** One piece cartridge design provides faster changeout and fewer potential gasket leaks than stacked cartridges.
- **Industry Qualified.** Velcon HV and HVS Series Horizontal Filters/Separators are fully qualified to API/EI 1581, Fifth Edition. These units incorporate one piece threaded base coalescer elements for easy, reliable installation and reusable one piece Teflon[®] coated screen separators.

SPECIFICATIONS

- 150 psi ASME Code Construction
- Victaulic Connections (Flanges Optional)
- Swing Bolted Closure
- Buna-N O-Ring Cover Seal
- Spider Assembly to stabilize cartridges
- MIL-PRF-4556 Epoxy Coated Interior, Primed Exterior
- Fittings for Pressure Relief Valve, Air Vent, and Pressure Gauge
- Sump is covered with plywood when shipped. Bolted steel cover is available as an option



Model No. HV1633M
A fully-qualified 300 USGPM Filter/Separator. End Opening unit is only 16 inches in diameter and 47 inches long.



Model No. HVS2228M
A fully-qualified 510 USGPM Filter/Separator. Side Opening unit is only 22 inches in diameter and 65 inches long.

[®] Teflon is a registered trademark of E.I. du Pont de Nemours & Co., Inc.

Horizontal Filter/Separators for Mobile Fueling

HVS Series Side Opening Vessels

A side opening vessel allows access to the cartridges from the main shell of the vessel. The cartridges are mounted in an “end opposed” configuration, with coalescers mounted on one end of the vessels and separators mounted on the other. These vessels are often used on refueling vehicles that require special orientation of the vessel for servicing the cartridges.

Velcon has qualified several side opening vessel configurations, shown below, for API/EI 1581 5th Edition, as follows: Category “C” vessels are for use in commercial Jet-A or Jet-A1 fuel. Type “S-LW” vessels can be used for mobile applications where minimal amounts of water can be expected in the jet fuel.



Photo courtesy of Rampmaster

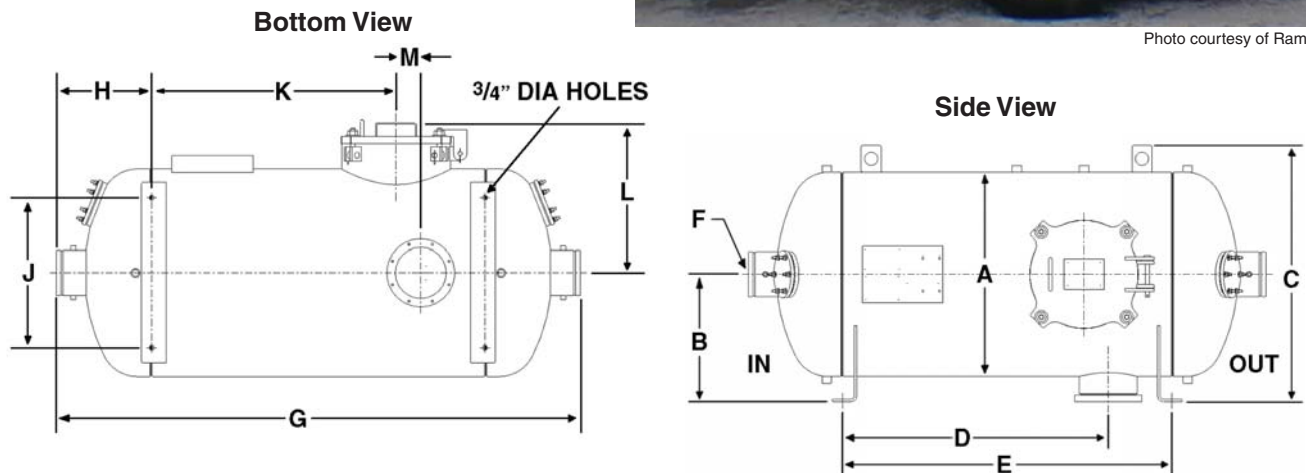

Side Opening Vessel Dimensions**

Vessel Model	Dimensions (Inches)													Wt w/Skid (lbs)	Vol (US Gal)
	A	B	C	D	E	F	G	H	J	K	L	M			
HVS2222M	22	14	29	30 1/2	41	4	60	9 1/2	16	30 1/2	16 1/2	0	1070	85	
HVS2228M	22	14	29	35 1/2	46	4	65	9 1/2	16	35 1/2	16 1/2	0	1100	95	
HVS2628M	26	16	32	36	45	6	71	13	21	30	19 1/2	6	1340	132	
HVS2828M	28	18	36	36	45	6	71	13	21	30	19 1/2	6	1580	150	
HVS3133M	31	19	38 1/4	36	49	6	77	14	22	36	22 1/2	0	2000	195	

**Dimensions shown are for estimating purposes only. For exact dimensional detail, obtain a certified copy of specific vessel drawing.

SIDE OPENING VESSELS CARTRIDGE SELECTION

Category C, Type S-LW

Vessel Model	Flow Rate (GPM)	Coalescer		Separator	
		Qty.	Model	Qty.	Model
HVS2222M	380	7	I-622C5TB	3	SO-609V5
HVS2228M	510	7	I-628C5TB	4	SO-609V5
HVS2628M	635	9	I-628C5TB	5	SO-609V5
HVS2828M	730	10	I-628C5TB	6	SO-609V5
HVS3133M	1020	12	I-633C5TB	8	SO-609V5

HV Series

End Opening Vessels

The coalescer and separator cartridges on end opening vessels are mounted on the same end. These vessels are normally used on refueling vehicles.

Velcon has qualified several end opening vessels configurations, shown below, for API/EI 1581 5th Edition, as follows: Category "C" vessels are for use in commercial Jet-A or Jet-A1 fuel. Category "M" vessels are for use in military JP-8 or JP-5 fuel. Testing to Category "M" qualifies for both Category "M" and Category "C".

Type "S-LW" vessels are used for mobile applications where minimal amounts of water can be expected in the jet fuel. Type "S" filter/separators are used locations where significant levels of both dirt and water can be expected.



Bottom View

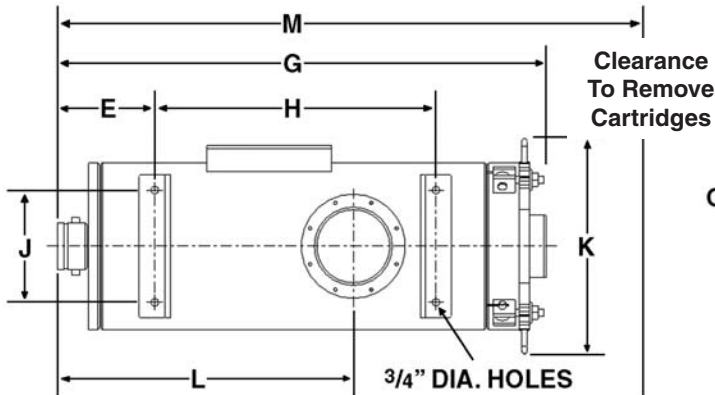

Side View

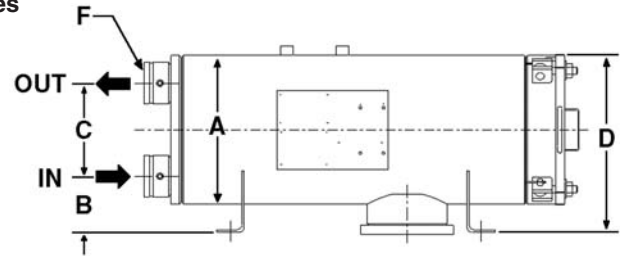

End Opening Vessel Dimensions**

Vessel Model	Dimensions (Inches)												Wt w/Skid (lbs)	Vol (US Gal)
	A	B	C	D	E	F	G	H	J	K	L	M		
HV1416M	14	6 3/4	8 1/8	17 3/8	4 7/8	2	30 3/4	20 1/4	10 3/4	18 9/16	15 9/16	45	400	18
HV1622M	16	6	10	19	9 3/8	4	36 13/16	16	10 3/4	20 5/8	17 1/4	56	440	32
HV1633M	16	6	10	19	9 5/16	4	46 7/8	27	10 3/4	20 5/8	28 3/8	79	450	42
HV2233M	22	10 1/2	10	30	11 1/2	4	52 11/16	29	16	27 1/16	29	85	800	69
HV2238M	22	10 1/2	10	30	11 1/2	4	55	34	16	27 1/16	37 3/4	92	835	77
HV2244M	24	9	12 1/2	30	15	6	63 13/16	31 1/2	16	27 1/16	32 7/8	107	870	87
HV2456M	24	12	11 1/2	33	15 3/16	6	72 11/16	38	18	33 1/32	36 3/16	125	1255	124
HV2828M	28	10 1/2	16 3/4	36	12	6	55 3/8	22 1/2	21	34 5/8	23 1/4	69	1210	120
HV2833M	28	10 1/2	16 3/4	36	12	6	61 1/16	28	21	34 5/8	23 1/4	83	1255	135
HV2838M	28	10 1/2	16 3/4	36	12	6	59 15/16	28	21	34 5/8	23 1/4	85	1300	150
HV2844M	28	10 1/2	16 3/4	36	12	6	64 1/2	29	21	34 5/8	23 1/4	98	1350	166
HV2856M	28	10 1/2	16 3/4	36	12	6	75 25/32	41	21	34 5/8	23 1/4	119	1460	198

**Dimensions shown are for estimating purposes only. For exact dimensional detail, obtain a certified copy of specific vessel drawing.

END OPENING VESSELS CARTRIDGE SELECTION

Vessel Model	Category	Type	Flow Rate (GPM)	Cover Style	Coalescer		Separator	
					Qty	Model	Qty	Model
HV1416M	M	S	70	Flat	2	I-616MMTB	1	SO-318V5
	C	S-LW	90			I-616C5TB		
HV1622M	M	S	70	Flat	3	I-622MMTB	1	SO-424V5
	C	S-LW	190			I-622C5TB		
HV1633M	M	S	240	Flat	3	I-633MMTB	1	SO-436V5
	C	S-LW	300			I-633C5TB		
HV2233M	C	S-LW	425	Flat	4	I-633C5TB	1	SO-424V
	M	S	305			I-633MMTB		SO-424V5
HV2238M	C	S-LW	495	Flat	4	I-638C5TB	2	SO-430V
	M	S	365			I-638MMTB		SO-430V5
HV2244M	C	S-LW	580	Flat	4	I-644C5TB	2	SO-636V
	M	S	425			I-644MMTB		SO-636V5
HV2456M	C	S-LW	640	Flat	4	I-656C5TB	2	SO-624V
	M	S	405			I-656MMTB		SO-624V5
HV2828M	C	S-LW	615	Dome	7	I-628C5TB	2	SO-636V
	M	S	455			I-628MMTB		SO-636V5
HV2833M	C	S-LW	740	Dome	7	I-633C5TB	2	SO-636V
	M	S	550			I-633MMTB		SO-636V5
HV2838M	C	S-LW	865	Dome	7	I-638C5TB	2	SO-636V
	M	S	615			I-638MMTB		SO-636V5
HV2844M	C	S-LW	1015	Dome	7	I-644C5TB	2	SO-640V
	M	S	690			I-644MMTB		SO-640V5
HV2856M	C	S-LW	1310	Dome	7	I-656C5TB	2	SO-648V
	M	S	830			I-656MMTB		SO-648V5



Velcon products are sold and serviced by a world-wide representative network. To order, contact Headquarters or your **LOCAL REPRESENTATIVE**:

COMPANY HEADQUARTERS:
 Velcon Filters, Inc.
 1210 Garden of the Gods Road
 Colorado Springs, CO 80907-3410
 Phone: 1.800.531.0180 / 1.719.531.5855
 Fax: 719.531.5690
 e-mail: vfsales@velcon.com
 www.velcon.com

MANUFACTURING PLANTS LOCATED AT:
 Colorado Springs, Colorado
 Sylacauga, Alabama
 Henryetta, Oklahoma

OVERSEAS AFFILIATES:
 Frankfurt/M., Germany & Singapore

**Liquid Filtration
 and Separation
 Specialists**