

Vel-Max<sup>®</sup>  
Filter Vessel  
VESSEL MANUAL



Velcon Filters, LLC  
1210 Garden of the Gods Road  
Colorado Springs CO 80907  
Phone (719) 531-5855  
Toll-Free (800) 531-0180  
Fax (719) 531-5690

## TABLE OF CONTENTS

<b>GENERAL DESCRIPTION</b> .....	<b>4</b>
<b>INSTALLATION OF VESSEL</b> .....	<b>6</b>
<b>VEL-MAX® CONFIGURATIONS</b> .....	<b>7</b>
<b>START-UP PROCEDURE</b> .....	<b>8</b>
(VESSEL ON PRESSURE SIDE OF CENTRIFUGAL PUMP) .....	8
<b>START-UP PROCEDURE</b> .....	<b>9</b>
(VESSEL ON SUCTION SIDE OF PUMP).....	9
<b>FILTER/SEPARATOR</b> .....	<b>10</b>
DESCRIPTION.....	10
Filter/Separator Cartridge Installation.....	11
<b>FUEL MONITOR USING CDF® CARTRIDGES</b> .....	<b>12</b>
DESCRIPTION.....	12
CDF® Monitor Cartridge Installation .....	13
<b>CLAY TREATER</b> .....	<b>14</b>
DESCRIPTION.....	14
LA-61801B Clay Treater Canister Installation .....	15
<b>FUEL MONITOR USING AVIATION (6" OD) Aquacon® CARTRIDGES</b> .....	<b>16</b>
DESCRIPTION.....	16
Aquacon® Monitor Cartridge Installation .....	17
<b>INDUSTRIAL PREFILTER (6-1/4" OD)</b> .....	<b>18</b>
DESCRIPTION.....	18
FO-7xxxx Prefilter Cartridge Installation.....	19
<b>AVIATION (6" OD) PREFILTER</b> .....	<b>20</b>
DESCRIPTION.....	20
FO-6xxxx Prefilter Cartridge Installation.....	21
<b>FUEL MONITOR USING INDUSTRIAL (6-1/4" OD) Aquacon® CARTRIDGE</b> .....	<b>22</b>
DESCRIPTION.....	22
<b>APPENDIX</b> .....	<b>24</b>
Figure 1	
Figure 2	
Figure 3	
Figure 4	
Vel-Max® Data Sheet (1961)	
Separator Cartridge Data Sheet (1521)	
Pleated Media Filter Cartridge Data Sheet (1549)	
Industrial Aquacon® Cartridge Data Sheet (1582)	
Adsorbent Cartridge Data Sheet (1667)	
ACO Aquacon® Cartridge Data Sheet (1681)	
CDF® N Series (1962)	
Synthetic Media (1734)	
Operating Procedures for Water Absorbing Cartridges (1839)	

**THIS PAGE INTENTIONALLY LEFT BLANK**

## GENERAL DESCRIPTION

The Velcon Vel-Max<sup>®</sup> vessel that you have received consists of the vessel and accessory equipment to meet your specific requirements. Descriptive literature covering the accessories is included near the back of this manual.

A variety of filter cartridges, and associated hardware kits, can be used with this vessel.

The Vel-Max vessel can be configured in 4 different ways. These are:

Pre-filter vessel, for particle removal

Filter/separator, for both water and particle removal

Fuel monitor, utilizing patented **Aquacon**<sup>®</sup> or CDF<sup>®</sup> cartridges

Clay treater, for surfactant removal

Each of these configurations are discussed in more detail following. See the specific section covering your configuration for cartridge installation, startup procedures, operating information, cartridge change-out, and other necessary information.

## INSTALLATION OF VESSEL

1. Identify the vessel inlet and outlet by the markings provided on the vessel piping connections. The inlet is near the top opening of the vessel; the outlet is at the bottom of the vessel. The vessel must be installed in the correct flow direction to perform properly and to avoid damage to the system. (Note: some filter cartridges flow opposite the normal flow direction. ADI cartridges require inlet flow to enter at the bottom of the vessel.)
2. Inlet and outlet piping should be carefully aligned to avoid stressing the vessel connections during installation. Installation of shut-off valves on both sides of the vessel is recommended to ease cartridge changeout or vessel inspection.

### **CAUTION: STEPS 3 AND 4 SHOULD BE PERFORMED BEFORE REMOVING HINGED COVER TO INSURE STABILITY OF THE VESSEL**

3. Insure that the leg assembly is bolted snugly to the vessel body.
4. Bolt the legs to a stable, horizontal base.
5. Adjust the vessel body to the necessary height, if required, by loosening the leg assembly and retightening after required vessel location has been achieved.
6. Thread appropriate fittings to the inlet and outlet connections. Use pipe dope or Teflon<sup>®</sup> thread to seal the threaded connections.
7. Connect any accessories that are not already installed. See Accessory Parts List and literature as required.
8. Cartridges are normally packed separately. Refer to the appropriate section for the configuration that you have purchased.
9. NOTE; THE VESSEL MUST BE PROVIDED WITH A PRESSURE RELIEF VALVE IF THE SYSTEM HAS POSITIVE DISPLACEMENT PUMPS UPSTREAM OR AUTOMATIC SHUT-OFF VALVES DOWNSTREAM OF THE VESSEL

## VEL-MAX<sup>®</sup> CONFIGURATIONS

The Vel-Max vessel can be configured in 4 different ways;

- Prefilter vessel, for particle removal
- Filter/separator, for both water and particle removal
- Fuel monitor, utilizing patented **Aquacon<sup>®</sup>** or CDF<sup>®</sup> cartridges
- Clay treater, for surfactant removal

Below is a listing of the kits required for each configuration. Make sure that your vessel includes the appropriate conversion kit for your configuration. Kit installation instructions are included with each conversion kit. Install the kit before proceeding.

Configuration	VX-1	VX-2	VX-3
<b>FILTER/SEPARATOR</b>	VX1-FSKIT	VX2-FSKIT	VX3-FSKIT
<b>AVIATION Aquacon<sup>®</sup> (6" OD)</b>	VX1-AVKIT	VX2-AVKIT	VX3-AVKIT
<b>AVIATION PREFILTER (6" OD)</b>	VX1-AVKIT	VX2-AVKIT	VX3-AVKIT
<b>INDUSTRIAL PREFILTER or CLAY CARTRIDGE (6.25" OD)</b>	VX1-INKIT	N/A	VX3-INKIT
<b>INDUSTRIAL Aquacon<sup>®</sup> (6.25" OD)</b>	VX1-INKIT	N/A	VX3-INKIT
<b>CDF<sup>®</sup> CARTRIDGES</b>	VX1-CDKIT	VX2-CDKIT	N/A

# START-UP PROCEDURE

## (VESSEL ON PRESSURE SIDE OF CENTRIFUGAL PUMP)

Place the below valves in these positions:

1. Manual drain valve – closed
2. Manual air eliminator – open
3. Inlet and outlet valves – both closed

Install appropriate filter cartridge(s). Consult cartridge installation instructions, which follow in this manual.

Replace vessel cover and torque bolts to 45-50 ft-lbs (62-68 N-m).

The vessel is now ready to be filled with the product.

The following operation instructions can be used for initial start-up and for subsequent start-ups after installation of replacement cartridges or servicing of the vessel.

1. Start the system pump.
2. Slightly open the inlet valve, allowing the vessel to slowly fill with the product. (Take about 10-15 minutes to fill the vessel to eliminate the possibility of an internal fire.)
3. If the unit is equipped with a manual air eliminator valve, leave the valve cracked open until the fluid flows from the opening; then close quickly.
4. If equipped with an automatic air eliminator, the unit is filled when the air eliminator stops flowing air. Then the Velcon vessel is filled with the product. Fully open the inlet valve, and slowly open the outlet valve.
5. When the unit is in operation, take a differential pressure reading and record the reading. The differential pressure ( $\Delta P$ ) should be between 1 and 10 depending on the purchase specification. If there is no  $\Delta P$ , the system should be shut down and the vessel inspected for broken seals or possibly elements left out. See differential pressure readings under OPERATING INFORMATION.

# START-UP PROCEDURE

## (VESSEL ON SUCTION SIDE OF PUMP)

Place the below valves in these positions:

1. Manual drain valve – closed
2. Manual cover valve– open
3. Inlet and outlet valves – both closed
4. Vessel cover open

Install appropriate filter cartridge(s). Consult cartridge installation instructions which follow in this manual.

The vessel is now ready to be filled with the product.

The following operation instructions can be used for initial start-up and for subsequent start-ups after installation of replacement cartridges or servicing of the vessel.

1. Obtain the product, place in bucket.
2. Pour the product into the top of the open vessel. Pour until vessel is almost full.
3. Close the cover and torque the bolts to 45-50 ft-lbs (62-68 N-m).
4. Using a funnel, completely fill the vessel by pouring fuel into the cover valve through the funnel. Be careful to minimize any spills. Close the cover valve when the vessel is full.
5. Open the inlet and outlet valves.
6. Start the system pump to begin flowing through the vessel.

When the unit is in operation, take a differential pressure reading and record the reading. The differential pressure ( $\Delta P$ ) should be between 1 and 10 depending on the purchase specification. If there is no  $\Delta P$ , the system should be shut down and the vessel inspected for broken seals or possibly elements left out. See differential pressure readings under OPERATING INFORMATION.

# **FILTER/SEPARATOR**

## **DESCRIPTION**

The Velcon Filter/Separator that you have received consists of the vessel, separately purchased first and second stage elements, and accessory equipment to meet your specific requirements. Descriptive literature covering the accessories is included near the back of this manual.

Velcon Filter/Separators are manufactured to meet a variety of different end uses and specifications. The finest workmanship has gone into the building of this Velcon Filter/Separator. It is of no value, however, if elements are improperly installed or the unit is improperly operated. We urge you to read the manual carefully and follow the instructions given.

A Velcon Filter/Separator is specifically designed to remove solid contaminants and water from the product. To accomplish this, the Filter/Separator is equipped with two types of cartridges through which the product passes in sequence.

### *First Stage – Coalescer Cartridges*

These cartridges have two functions. They filter solid contaminants out of the product and coalesce water into droplets. Any water present in the influent product is usually emulsified into tiny drops by the action of the pumps handling the product. The first stage cartridges coalesce these tiny drops into drops of sufficient size to settle out of the product rapidly.

### *Second Stage – Separator Cartridges*

The function of the second stage cartridges is to repel coalesced water droplets that have not yet settled so that they are prevented from going downstream with the product.

The water should be drained manually on a daily basis (automatic drain valves are not recommended). Proper provision for drainage of accumulated water is of key importance in the operation of any Filter/Separator. If the water level gets too high, it will be carried downstream.

## **Filter/Separator Cartridge Installation**

### **Separator cartridge**

1. Insure the tie rod is securely mounted.
2. Remove the separator cartridge from the packaging. Handle carefully by the end caps. **DO NOT TOUCH THE SURFACE OF THE SEPARATOR MEDIA.**
3. Install the separator cartridge over the tie rod. Make sure to center the separator on the mount and seat it squarely to achieve a good seal.
4. Install the seal plate, rubber gasket, flat washer, lock washer, and nut as shown in Figure 1.
5. Torque the nut as illustrated in Figure 1.

### **Coalescer cartridge**

1. Remove the coalescer cartridge from the packaging.
2. Install the coalescer cartridge over the separator cartridge previously installed. Center the cartridge in the vessel to achieve a good seal.
3. Install the seal plate, rubber gasket, flat washer, lock washer and nut as shown in Figure 1.
4. Torque the nut as illustrated in Figure 1.

**USE ONLY VELCON FILTERS LLC CARTRIDGES IN THIS FILTER/SEPARATOR. VELCON CANNOT WARRANT PERFORMANCE IF ANY OTHER MANUFACTURER'S CARTRIDGES ARE USED.**

To reorder cartridges and replacement parts or to obtain further information, contact your Velcon Filters, LLC. representative, or

Velcon Filters LLC  
1210 Garden of the Gods Rd  
Colorado Springs, CO 80907-3410  
Phone: 719-531-5855  
Fax: 719-531-5690  
Email: [vfsales@velcon.com](mailto:vfsales@velcon.com)  
Web site: [www.velcon.com](http://www.velcon.com)

# FUEL MONITOR USING CDF<sup>®</sup> CARTRIDGES

## DESCRIPTION

The Velcon Monitor vessel configuration that you have received consists of the vessel, separately purchased monitor cartridges, and accessories to meet your specific requirements. Descriptive literature covering the accessories is included elsewhere in this manual.

The Velcon Monitor vessel is specifically designed to absorb free water and remove solid contaminants from the product being filtered. Five CDF<sup>®</sup> cartridges are mounted on the adapter. The cartridges flow outside to inside.

### *CDF<sup>®</sup> Monitor Cartridges*

These cartridges absorb water and filter solids from avgas and jet fuel. They provide positive protection against water slug transmission. The cartridges are tested and qualified to EI 1583.

### **\*\*\*\*\*CAUTION\*\*\*\*\***

**DO NOT USE CDF<sup>®</sup> MONITOR CARTRIDGES  
WITH PRE-MIXED FUEL CONTAINING  
ANTI-ICING ADDITIVES (DiEGME, FIZZY<sup>®</sup>, Prist<sup>®</sup>, or FSII)**

## CDF® Monitor Cartridge Installation

1. Make sure that the proper conversion kit is installed for the CDF configuration.
2. Insure that the tie rod is securely mounted.
3. Remove the CDF cartridge from the packaging.
4. Install the cartridge by inserting the snout end into the adapter holes. Seat each cartridge firmly by giving it a slight twisting motion while pushing it into the hole.
5. Install the star-shaped spider down the tie rod over the ends of the cartridges. Install the nut onto the tied rod and tighten snugly to secure the spider.
6. Torque the nut as illustrated in Figure 2.
7. **NOTE: Vessel must be provided with pressure relief valve if the system has a positive displacement pump upstream or automatic shut-off valve downstream of the vessel.**

USE ONLY VELCON FILTERS LLC CARTRIDGES IN THIS FILTER. VELCON CANNOT WARRANT PERFORMANCE IF ANY OTHER MANUFACTURER'S CARTRIDGES ARE USED.

To reorder cartridges and replacement parts or to obtain further information, contact your Velcon Filters LLC representative, or

Velcon Filters LLC  
1210 Garden of the Gods Rd  
Colorado Springs CO 80907-3410  
Phone: 719-531-5855  
Fax: 719-531-5690  
Email: [vfsales@velcon.com](mailto:vfsales@velcon.com)  
Web site: [www.velcon.com](http://www.velcon.com)

# CLAY TREATER

## DESCRIPTION

The Velcon Clay Treater vessel configuration that you have received consists of the vessel, separately purchased clay cartridges, and accessories to meet your specific requirements. Descriptive literature covering the accessories is included elsewhere in this manual.

The Velcon Clay Treater vessel is specifically designed to remove surfactant material from the product being treated. One or more LA-61801B cartridges are mounted on the adapter. The cartridges flow outside-to-inside.

### ***LA-61801B Clay Canisters***

Attapulugus clay canisters are used to remove surfactants from jet fuel and other petroleum products.

## LA-61801B Clay Treater Canister Installation

1. Make sure that you have the proper installation kit for the LA-61801B clay treater canister. This will be same kit as used for the industrial (6-1/4" OD) prefilters.
2. Insure that the tie rod is securely mounted.
3. Remove the clay canister cartridge from the packaging.
4. Install the LA-61801B canister over the tie rod, making sure to center and squarely mount on the base to achieve a good seal..
5. If the vessel is a VX-3, install a spacer seal plate on top of the first canister.
6. Install another LA-61801B canister over the tie rod.
7. Install the seal plate, rubber gasket, flat washer, lock washer, and nut as shown in Figure 3
8. Torque the nut as illustrated in Figure 3

USE ONLY VELCON FILTERS LLC CARTRIDGES IN THIS FILTER. VELCON CANNOT WARRANT PERFORMANCE IF ANY OTHER MANUFACTURER'S CARTRIDGES ARE USED.

To reorder cartridges and replacement parts or to obtain further information, contact your Velcon Filters LLC representative, or

Velcon Filters LLC  
1210 Garden of the Gods Rd  
Colorado Springs CO 80907-3410  
Phone: 719-531-5855  
Fax: 719-531-5690  
Email: [vfsales@velcon.com](mailto:vfsales@velcon.com)  
Web site: [www.velcon.com](http://www.velcon.com)

## **FUEL MONITOR USING AVIATION (6" OD) *Aquacon*<sup>®</sup> CARTRIDGES**

### **DESCRIPTION**

The Velcon Monitor vessel configuration that you have received consists of the vessel, separately purchased monitor cartridge, and accessories to meet your specific requirements. Descriptive literature covering the accessories is included elsewhere in this manual.

The Velcon Monitor vessel is specifically designed to absorb free water and remove solid contaminants from the product being filtered. The *Aquacon*<sup>®</sup> cartridge is mounted on the center mount. The cartridge flows outside to inside.

ADI cartridges flow inside to outside. The vessel flow direction must be reversed, with the inlet at the bottom, to use these cartridges. Make sure the flow direction is correct when using this cartridge family.

### ***Aquacon*<sup>®</sup> Monitor Cartridges**

These cartridges absorb water and filter solids from avgas and jet fuel. They provide positive protection against water slug transmission. The cartridges are tested and qualified to EI 1583.

**\*\*\*\*\*CAUTION\*\*\*\*\***

**DO NOT USE *Aquacon*<sup>®</sup> MONITOR CARTRIDGES  
WITH PRE-MIXED FUEL CONTAINING  
ANTI-ICING ADDITIVES (DiEGME, FIZZY<sup>®</sup>, Prist<sup>®</sup>, or FSII)**

## **Aquacon® Monitor Cartridge Installation**

1. Make sure that you have the proper installation kit for the 6" OD **Aquacon** monitor cartridge.
2. Insure that the tie rod is securely mounted.
3. Remove the **Aquacon** cartridge from the packaging.
4. Install the cartridge by inserting over the tie rod, making sure the bottom cap is centered and squarely mounted to the base to achieve a good seal.
5. If the vessel is a VX2, install the necessary spacer seal plate to center and seal the filters. Install another filter on top of the seal plate.
6. If the vessel is a VX3, install another spacer seal plate. Install another filter on top of the seal plate.
7. Install the seal plate, rubber washer, flat washer, lock washer and nut as illustrated in Figure 2.
8. Torque the nut as illustrated in Figure 4.
9. **NOTE: Vessel must be provided with pressure relief valve if the system has a positive displacement pump upstream or automatic shut-off valve downstream of the vessel.**

USE ONLY VELCON FILTERS LLC CARTRIDGES IN THIS FILTER. VELCON CANNOT WARRANT PERFORMANCE IF ANY OTHER MANUFACTURER'S CARTRIDGES ARE USED.

To reorder cartridges and replacement parts or to obtain further information, contact your Velcon Filters LLC representative, or

Velcon Filters LLC  
1210 Garden of the Gods Rd  
Colorado Springs CO 80907-3410  
Phone: 719-531-5855  
Fax: 719-531-5690  
Email: [vfsales@velcon.com](mailto:vfsales@velcon.com)  
Web site: [www.velcon.com](http://www.velcon.com)

## **INDUSTRIAL PREFILTER (6-1/4" OD)**

### **DESCRIPTION**

The Velcon Prefilter vessel configuration that you have received consists of the vessel, separately purchased filter cartridges, and accessories to meet your specific requirements. Descriptive literature covering the accessories is included elsewhere in this manual.

The Velcon Prefilter vessel is specifically designed to remove solid particles from the product being treated. The FO-7xxxx cartridges are mounted on the vessel base. The cartridges flow outside-to-inside.

### ***FO-7xxxx Filter Cartridges***

Prefilter cartridges are used to remove particles from jet fuel, oils, and other petroleum products.

## **FO-7xxxx Prefilter Cartridge Installation**

1. Make sure that you have the proper installation kit for the 6-1/4" OD FO-7xxxx prefilter.
2. Insure that the tie rod is securely mounted.
3. Remove the prefilter cartridge from the packaging.
4. Install the filter over the tie rod, making sure to center and squarely mount on the base to achieve a good seal.
5. If the vessel is a VX3, install the necessary spacer seal plate.
6. Install another filter over the spacer seal plate.
7. Install the seal plate, rubber gasket, flat washer, lock washer, and nut as shown in Figure 3
8. Torque the nut as illustrated in Figure 3

USE ONLY VELCON FILTERS LLC CARTRIDGES IN THIS FILTER. VELCON CANNOT WARRANT PERFORMANCE IF ANY OTHER MANUFACTURER'S CARTRIDGES ARE USED.

To reorder cartridges and replacement parts or to obtain further information, contact your Velcon Filters LLC representative, or

Velcon Filters LLC  
1210 Garden of the Gods Rd  
Colorado Springs CO 80907-3410  
Phone: 719-531-5855  
Fax: 719-531-5690  
Email: [vfsales@velcon.com](mailto:vfsales@velcon.com)  
Web site: [www.velcon.com](http://www.velcon.com)

# AVIATION (6" OD) PREFILTER

## DESCRIPTION

The Velcon Prefilter vessel configuration that you have received consists of the vessel, separately purchased filter cartridges, and accessories to meet your specific requirements. Descriptive literature covering the accessories is included elsewhere in this manual.

The Velcon Prefilter vessel is specifically designed to remove solid particles from the product being treated. The FO-6xxxx cartridges are mounted on the vessel base. The cartridges flow outside-to-inside.

### ***FO-6xxxx Filter Cartridges***

Prefilter cartridges are used to remove particles from jet fuel, and other petroleum fuels.

## FO-6xxxx Prefilter Cartridge Installation

1. Make sure that you have the proper installation kit for the 6" OD aviation prefilter.
2. Insure that the tie rod is securely mounted.
3. Remove the prefilter cartridge from the packaging.
4. Install the filter over the tie rod, making sure to center and squarely mount on the base to achieve a good seal..
5. If the vessel is a VX2, install the necessary spacer seal plate on top of the filter. Install another filter on top of the seal plate.
6. If the vessel is a VX3, install another spacer seal plate and another filter.
7. Install the seal plate, rubber gasket, flat washer, lock washer, and nut as shown in Figure 2.
8. Torque the nut as illustrated in Figure 4.

USE ONLY VELCON FILTERS LLC CARTRIDGES IN THIS FILTER. VELCON CANNOT WARRANT PERFORMANCE IF ANY OTHER MANUFACTURER'S CARTRIDGES ARE USED.

To reorder cartridges and replacement parts or to obtain further information, contact your Velcon Filters LLC representative, or

Velcon Filters LLC  
1210 Garden of the Gods Rd  
Colorado Springs CO 80907-3410  
Phone: 719-531-5855  
Fax: 719-531-5690  
Email: [vfsales@velcon.com](mailto:vfsales@velcon.com)  
Web site: [www.velcon.com](http://www.velcon.com)

## **FUEL MONITOR USING INDUSTRIAL (6-1/4" OD) *Aquacon*<sup>®</sup> CARTRIDGES**

### **DESCRIPTION**

The Velcon Monitor vessel configuration that you have received consists of the vessel, separately purchased monitor cartridge, and accessories to meet your specific requirements. Descriptive literature covering the accessories is included elsewhere in this manual.

The Velcon Monitor vessel is specifically designed to absorb free water and remove solid contaminants from the product being filtered. The *Aquacon*<sup>®</sup> cartridge is mounted on the center mount. The cartridge flows outside to inside.

### ***Aquacon*<sup>®</sup> Monitor Cartridges**

These cartridges absorb water and filter solids from lubricating and other oils. They provide positive protection against water slug transmission.

## Industrial *Aquacon*<sup>®</sup> Monitor Cartridge Installation

1. Make sure that you have the proper installation kit for the 6-1/4" OD industrial *Aquacon* cartridge.
2. Insure that the tie rod is securely mounted.
3. Remove the *Aquacon* AC-7xxxx cartridge from the packaging.
4. Install the cartridge by inserting over the tie rod, making sure the bottom cap is centered and squarely mounted to the base to achieve a good seal.
5. If the vessel is a VX3, install the necessary spacer seal plate to center and seal the top of the filter. Install another filter on top of the seal plate.
6. Install the seal plate, rubber washer, flat washer, lock washer and nut as illustrated in Figure 3.
7. Torque the nut as illustrated in Figure 3.
8. **NOTE: Vessel must be provided with pressure relief valve if the system has a positive displacement pump upstream or automatic shut-off valve downstream of the vessel.**

USE ONLY VELCON FILTERS LLC CARTRIDGES IN THIS FILTER. VELCON CANNOT WARRANT PERFORMANCE IF ANY OTHER MANUFACTURER'S CARTRIDGES ARE USED.

To reorder cartridges and replacement parts or to obtain further information, contact your Velcon Filters LLC representative, or

Velcon Filters LLC  
1210 Garden of the Gods Rd  
Colorado Springs CO 80907-3410  
Phone: 719-531-5855  
Fax: 719-531-5690  
Email: [vfsales@velcon.com](mailto:vfsales@velcon.com)  
Web site: [www.velcon.com](http://www.velcon.com)

**THIS PAGE INTENTIONALLY LEFT BLANK**

# APPENDIX

**THIS PAGE INTENTIONALLY LEFT BLANK**

# FIGURE 1

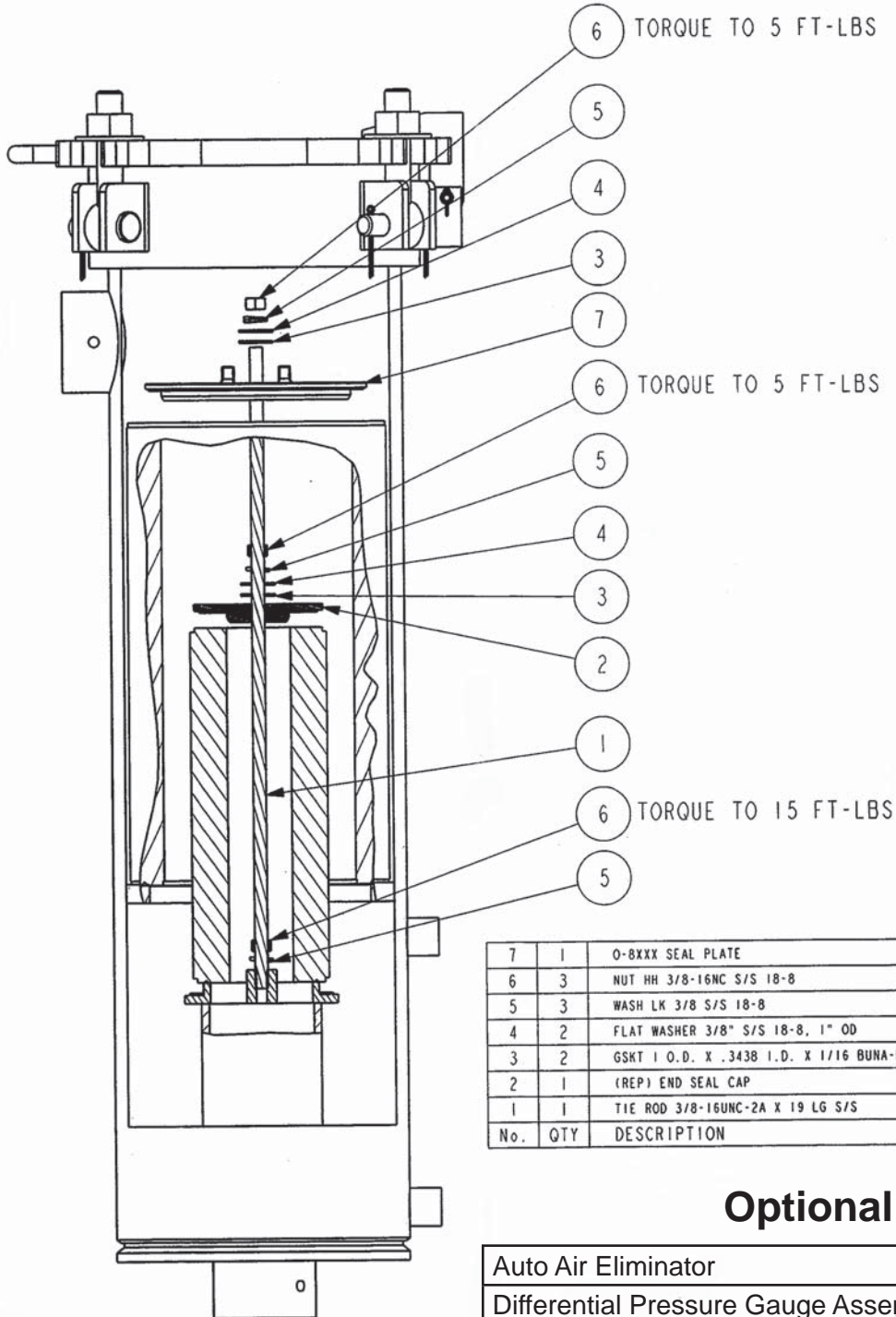

7	1	O-8XXX SEAL PLATE	EA35
6	3	NUT HH 3/8-16NC S/S 18-8	K07
5	3	WASH LK 3/8 S/S 18-8	K05
4	2	FLAT WASHER 3/8" S/S 18-8, 1" OD	K06
3	2	GSKT 1 O.D. X .3438 I.D. X 1/16 BUNA-N	G-0305
2	1	(REP) END SEAL CAP	12-02MMOD
1	1	TIE ROD 3/8-16UNC-2A X 19 LG S/S	T19.0-6
No.	QTY	DESCRIPTION	P/N

## Optional Accessories

Auto Air Eliminator	101-G
Differential Pressure Gauge Assembly	703X008
Manual Drain Valve	115-I
Pressure Relief Valve	130-BU
Sight Glass	138-P

# FIGURE 2

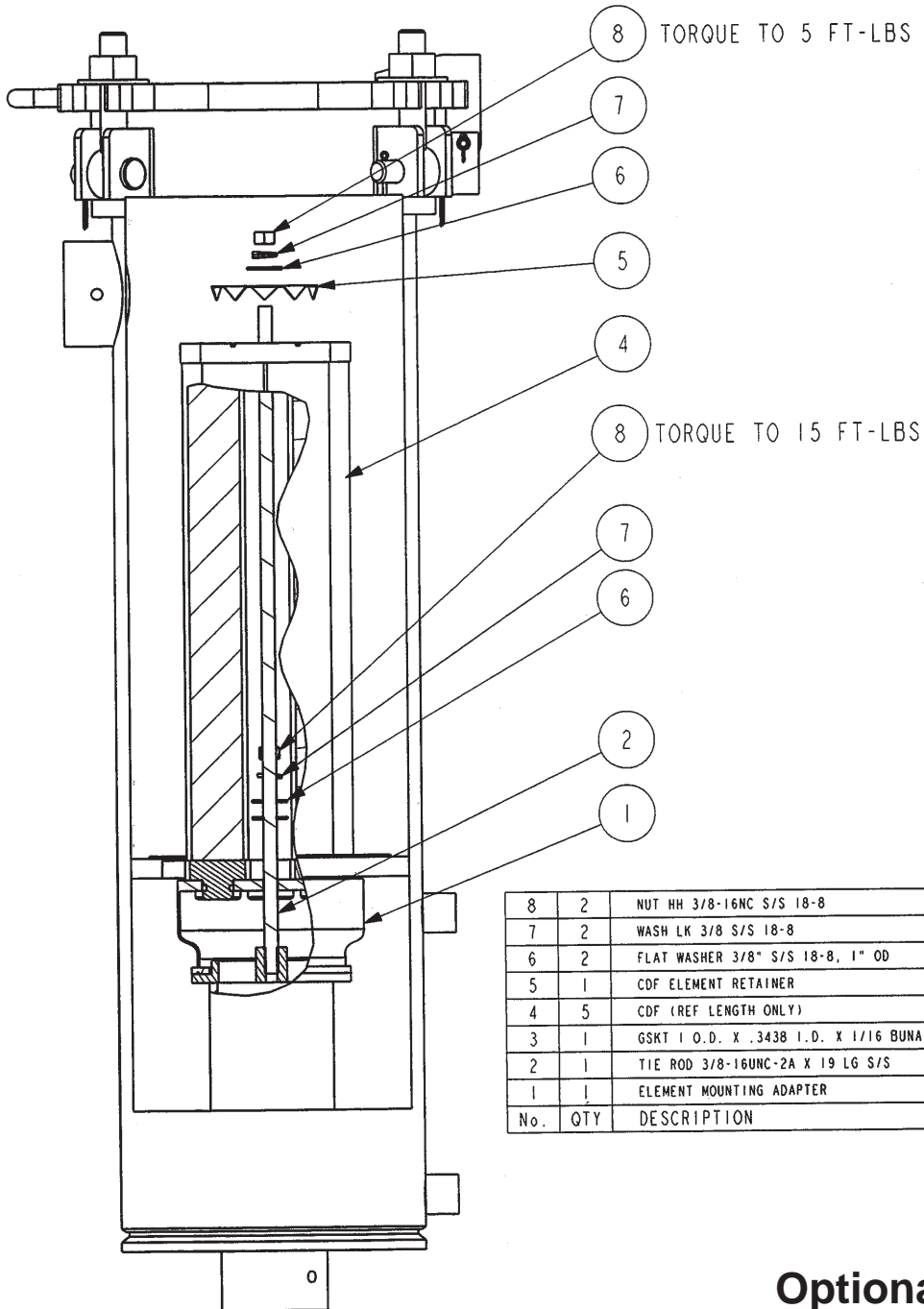

8	2	NUT HH 3/8-16NC S/S 18-8	K07
7	2	WASH LK 3/8 S/S 18-8	K05
6	2	FLAT WASHER 3/8" S/S 18-8, 1" OD	K06
5	1	CDF ELEMENT RETAINER	N94
4	5	CDF (REF LENGTH ONLY)	CDF-215K
3	1	GSKT 1 O.D. X .3438 I.D. X 1/16 BUNA-N	G-0305
2	1	TIE ROD 3/8-16UNC-2A X 19 LG S/S	T19.0-6
1	1	ELEMENT MOUNTING ADAPTER	EA3
No.	QTY	DESCRIPTION	P/N

## Optional Accessories

Auto Air Eliminator	101-G
Differential Pressure Gauge Assembly	703X008
Manual Drain Valve	115-I
Pressure Relief Valve	130-BU
Sight Glass	138-P

# FIGURE 3

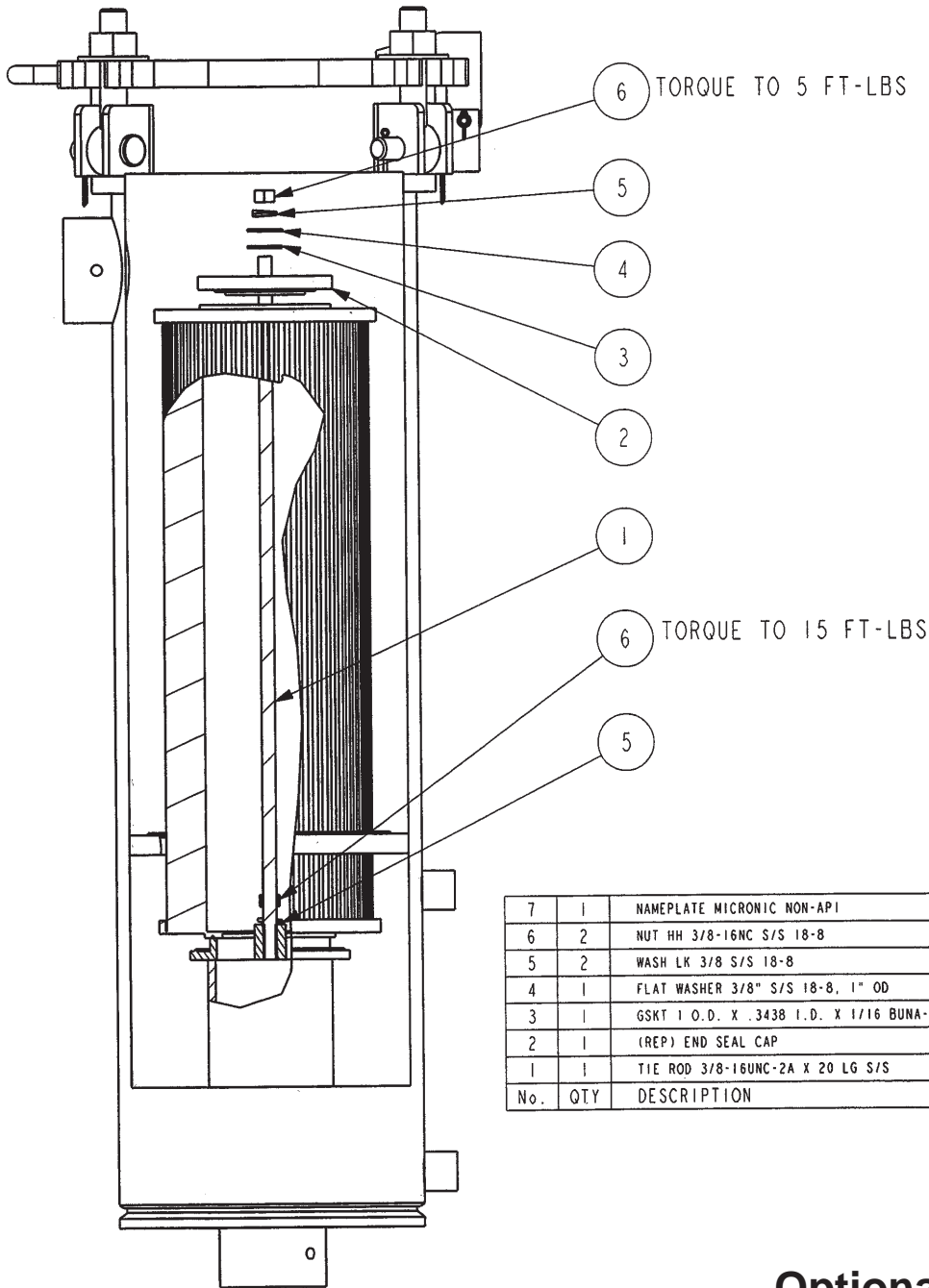

7	1	NAMEPLATE MICRONIC NON-API	N47
6	2	NUT HH 3/8-16NC S/S 18-8	K07
5	2	WASH LK 3/8 S/S 18-8	K05
4	1	FLAT WASHER 3/8" S/S 18-8, 1" OD	K06
3	1	GSKT 1 O.D. X .3438 I.D. X 1/16 BUNA-N	G-0305
2	1	(REP) END SEAL CAP	12-02M
1	1	TIE ROD 3/8-16UNC-2A X 20 LG S/S	T20.0-6
No.	QTY	DESCRIPTION	P/N

## Optional Accessories

Auto Air Eliminator	101-G
Differential Pressure Gauge Assembly	703X008
Manual Drain Valve	115-I
Pressure Relief Valve	130-BU
Sight Glass	138-P

# FIGURE 4

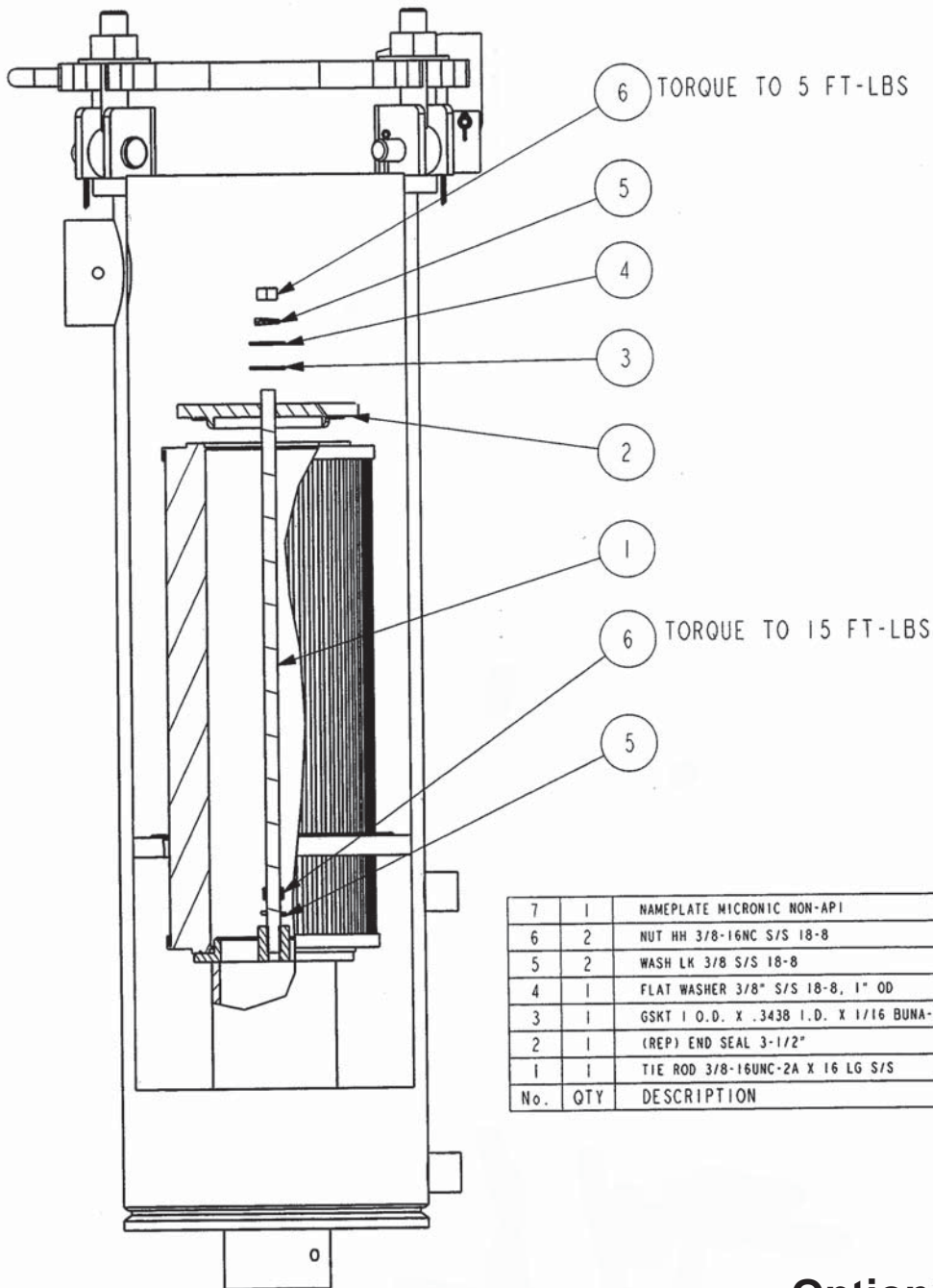

7	1	NAMEPLATE MICRONIC NON-API	N47
6	2	NUT HH 3/8-16NC S/S 18-8	K07
5	2	WASH LK 3/8 S/S 18-8	K05
4	1	FLAT WASHER 3/8" S/S 18-8, 1" OD	K06
3	1	GSKT 1 O.D. X .3438 I.D. X 1/16 BUNA-N	G-0305
2	1	(REP) END SEAL 3-1/2"	12-02C
1	1	TIE ROD 3/8-16UNC-2A X 16 LG S/S	T16.0-6
No.	QTY	DESCRIPTION	P/N

## Optional Accessories

Auto Air Eliminator	101-G
Differential Pressure Gauge Assembly	703X008
Manual Drain Valve	115-I
Pressure Relief Valve	130-BU
Sight Glass	138-P

- **Compact**
- **Flexible Filtration**
- **Multipurpose Design**
- **Simplified Maintenance**

## DESCRIPTION

The compact Vel-Max<sup>®</sup> Filter Vessel is suitable for flowrates up to 204 USGPM with micron cartridges, up to 198 USGPM as a filter/separator, and up to 150 USGPM with CDF<sup>®</sup> monitor cartridges. The Vel-Max<sup>®</sup> can be used on mobile refueling equipment, fueling cabinets and for fixed fueling installations. Vel-Max<sup>®</sup> is designed for easy maintenance and easy conversion to a prefilter, filter/separator, or monitor.

## APPLICATIONS

- Jet Fuel
- Avgas
- Motor Gasoline
- Diesel Fuel
- Kerosene
- Turbine Lube Oil
- Insulating Oil
- Biodiesel Blends

## STANDARD FEATURES

- Carbon steel construction
- 250 psi design pressure
- Epoxy powder coated interior & exterior
- 2" NPT female inlet/outlet
- 1/2" NPT drain connection
- 3/4" NPT vent and relief connection
- 1/2" NPT sight glass connections
- 1" NPT water probe connection
- 1/8" NPT differential pressure gauge connections
- Lid Gasket: G-2052 (Buna N)



**Vel-Max<sup>®</sup> Filter Vessel, VX-2, showing optional leg assembly, differential pressure gauge, sight glass assembly, and air eliminator.**

## OPTIONAL FEATURES

- Air eliminator
- Drain valve
- Pressure relief valve
- Water probe
- Sight gauge
- Leg assembly with adjustable height
- ASME Code Stamp
- CE Mark
- Differential pressure gauge assembly
- Lid Gasket: G-2052V (Viton)

# Vel-Max® Filter Vessel Configurations/Applications

## Filter/Separator Configuration

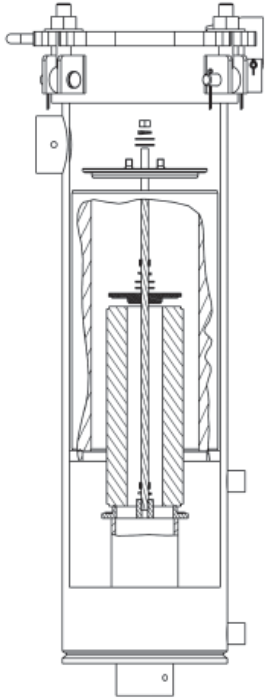

Vel-Max® Series for liquid/liquid separation uses a 2-stage coalescer separator cartridge combination to remove free and emulsified water from a liquid product stream. The first stage coalescing cartridge provides filtration as well as coalescing of free and emulsified water. The second stage separator is a hydrophobic barrier designed to repel the coalesced water droplets. The water droplets will fall and collect in the sump for removal through the manual drain.

## 6" or 6.25" OD x 2.625" ID Configuration

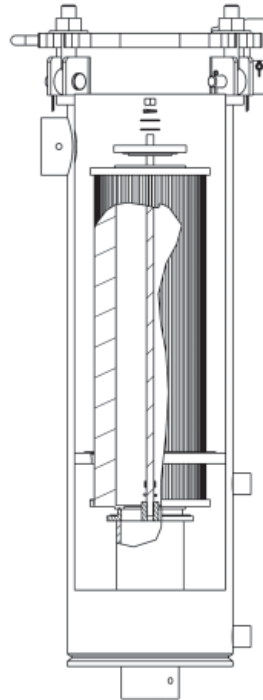

Vel-Max® Series for 6" or 6.25" OD x 2.625" ID cartridges can be used in several ways. To remove solid contaminants from a flow stream, use the vessel with a pleated media filter. When used with **Aquacon**® cartridges the Vel-Max® will remove solids and free water by absorption from a fuel or industrial oil flow stream. Using Vel-Max® with clay cartridges will remove surfactants, color and other impurities by adsorption from a fuel or industrial oil system.

## 6" OD x 3.5" ID Configuration

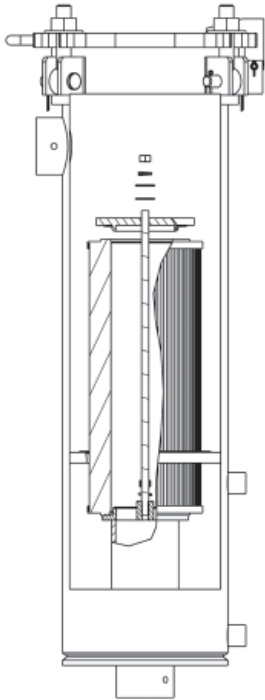

Vel-Max® Series with 6" OD x 3.5" ID cartridges can be used in two ways. To remove solid contaminants from a flow stream, use the vessel with a pleated media filter. When used with **Aquacon**® cartridges\* the Vel-Max® will remove solid contaminants and free water by absorption from a jet fuel or aviation gasoline flow stream.

## CDF® Monitor Configuration

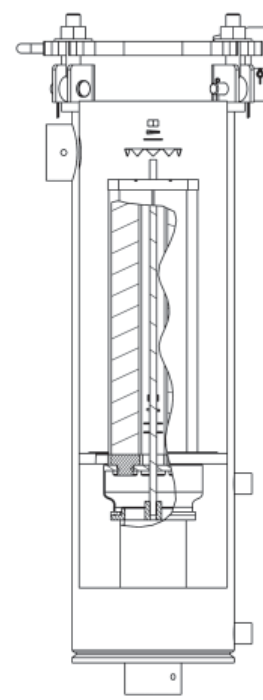

Vel-Max® Series can be adapted to use 2" diameter CDF® type monitor cartridges\* for removing solid contaminants and free water by absorption from jet fuel or aviation gasoline flow streams.

**\*CAUTION: Do not use Aquacon® or CDF® water absorbing monitor cartridges in pre-mixed jet fuel containing anti-icing additives (DiEGME, FIZZY®, Prist®, FSII)**

# Vel-Max® Filter Vessel Specifications

## DIMENSIONS

Model	Height		Cover Width		Cover Length		Dry Weight	
	Inches	mm	Inches	mm	Inches	mm	lbs	kgs
VX-1	36	914	13 7/16	341	11 5/8	295	110	50
VX-2	51	1295	13 7/16	341	11 5/8	295	125	57
VX-3	66	1676	13 7/16	341	11 5/8	295	150	68

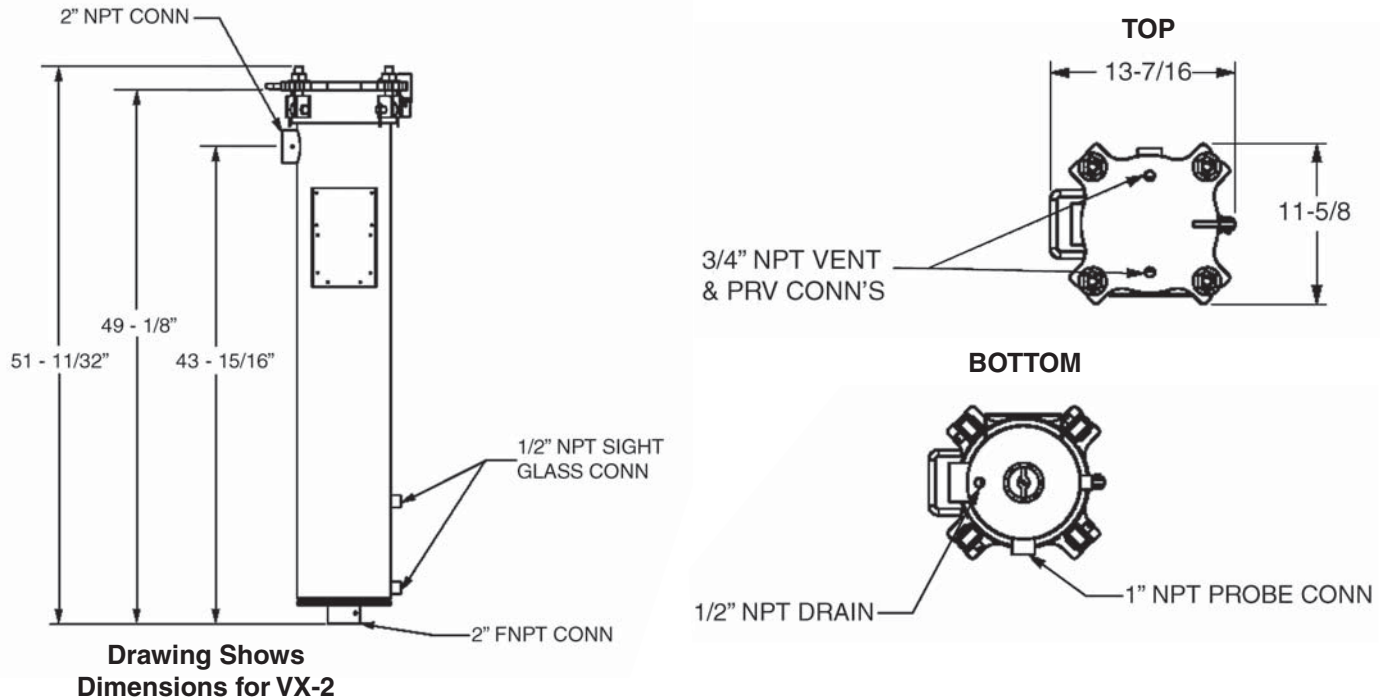

Dimensions shown are for estimating purposes only.  
For exact dimensional detail, obtain certified copy of vessel drawing.

## FLOW RATES

CONFIGURATION	APPLICATIONS	VX-1	VX-2	VX-3
FILTER / SEPARATOR	TURBINE LUBE OIL (ISO 32, 100°F)	3.5 USGPM	7.5 USGPM	11.5 USGPM
	INSULATING OIL (80°F)	6.1 USGPM	13.5 USGPM	20.0 USGPM
	DIESEL FUEL	25 USGPM	50 USGPM	75 USGPM
	GASOLINE / AVIATION GASOLINE	66 USGPM	132 USGPM	198 USGPM
	JET FUEL / KEROSENE	50 USGPM	100 USGPM	150 USGPM
MICRONIC CARTRIDGES 6" OD x 3.5" ID	OILS	CONTACT FACTORY		
	DIESEL FUEL	50 USGPM	100 USGPM	150 USGPM
	GASOLINE / AVIATION GASOLINE	68 USGPM	136 USGPM	204 USGPM
	JET FUEL / KEROSENE	66 USGPM	132 USGPM	198 USGPM
AVIATION <b>Aquacon</b> ® CARTRIDGES 6" OD x 3.5" ID	JET FUEL / KEROSENE	58 USGPM	115 USGPM	176 USGPM
INDUSTRIAL MICRONIC & <b>Aquacon</b> ® CARTRIDGES 6" or 6.25" OD x 2.625" ID	OILS	CONTACT FACTORY		
	DIESEL / GASOLINE / AV GAS / JET FUEL / KEROSENE	50 USGPM	100 USGPM	150 USGPM
CLAY CARTRIDGES (LA-61801B)	INSULATING OIL	1 USGPM	N/A	2 USGPM
	JET FUEL / KEROSENE / GASOLINE	7.5 USGPM		15 USGPM
CDF® MONITOR CARTRIDGES	JET FUEL / KEROSENE / GASOLINE	75 USGPM	150 USGPM	N/A

# Vel-Max® Cartridge Selection Table

## CARTRIDGES

FILTER/SEPARATOR CONFIGURATION				
FIRST STAGE COALESCERS FOR:	MICRON RATING	VX-1	VX-2	VX-3
DIESEL FUEL	25	O-8150	O-8300	O-8440
	3	O-8154	O-8304	O-8444
DIESEL FUEL / GASOLINE	2	O-8156	O-8306	O-8446
JET FUEL / KEROSENE / DIESEL FUEL / TURBINE LUBE OIL / INSULATING OIL	0.5	O-81588	O-83088	O-84488
SECOND STAGE SEPARATORS FOR:	TYPE	VX-1	VX-2	VX-3
DIESEL	PAPER	SO-415PL	SO-430PL	SO-444PL
JET / KERO / GAS / OILS	TCS	SO-415VX5	SO-430VX5	SO-444C
6" OD X 3.5" ID CONFIGURATION	TYPE	VX-1	VX-2	VX-3
MICRONIC CARTRIDGES	PLEATED PAPER	FO-614PLFxx	FO-614PLFxx (STACK OF 2)	FO-614PLFxx (STACK OF 3)
			FO-629PLFxx	FO-644PLFxx
	FIBERGLASS DEPTH	FO-614FGxx	FO-614FGxx (STACK OF 2)	FO-614FGxx (STACK OF 3)
			FO-629FGxx	FO-644FGxx
AVIATION <i>Aquacon</i> ® CARTRIDGES*		ACO-61401L	ACO-61401L (STACK OF 2)	ACO-61405 (STACK OF 3)
			ACO-62901L	ACO-61401L (STACK OF 3)
INDUSTRIAL <i>Aquacon</i> ® CARTRIDGES		AC-61405	A(C/D)-614xx (STACK OF 2)	A(C/D)-614xx (STACK OF 3)
		AD-61410		
		AD-61425	AC-62905	AC-64405
6" OR 6.25" OD X 2.625" ID CONFIGURATION		VX-1	VX-2	VX-3
MICRONIC CARTRIDGES	PLEATED PAPER (FO) & PLEATED SYNTHETIC (FOS)	FO-718PLxx	N/A	(FO/FOS)-718xx (STACK OF 2)
		FOS-618PLxx		FO-736PLxx
		FOS-718PLxx		FOS-636PLxx
	FIBERGLASS DEPTH	FO-618FGAxx		FO-618FGAxx (STACK OF 2)
		FO-636FGAxx		
INDUSTRIAL <i>Aquacon</i> ® CARTRIDGES		AC-718xx	AC-718xx (STACK OF 2)	
			AC-736xx	
CLAY (FULLER'S EARTH) CARTRIDGES		LA-61801B	LA-61801B (STACK OF 2)	
CDF® MONITOR CONFIGURATION		VX-1	VX-2	VX-3
CDF® CARTRIDGES*		CDF-215N	CDF-230N	N/A

The suffix "xx" on the part number of cartridges denotes the micron rating of the cartridge.  
Contact Velcon Filters, Inc. for available micron ratings.

## HARDWARE KITS

CONFIGURATION	VX-1	VX-2	VX-3
FILTER / SEPARATOR (COALESCER + SEPARATOR)	VX1-FSKIT	VX2-FSKIT	VX3-FSKIT
6" OD X 3.5" ID CARTRIDGE(S)	VX1-AVKIT	VX2-AVKIT	VX3-AVKIT
6" OR 6.25" OD X 2.625" ID CARTRIDGE(S)	VX1-INKIT	N/A	VX3-INKIT
CDF® MONITOR CARTRIDGES	VX1-CDKIT	VX2-CDKIT	N/A

**\*CAUTION: Do not use *Aquacon*® or CDF® water absorbing monitor cartridges in pre-mixed jet fuel containing anti-icing additives (DiEGME, FIZZY®, Prist®, FSII)**



Velcon products are sold and serviced by a world-wide representative network. To order, contact Headquarters or your LOCAL REPRESENTATIVE:

**COMPANY HEADQUARTERS:**  
 Velcon Filters, Inc.  
 1210 Garden of the Gods Road  
 Colorado Springs, CO 80907-3410  
 Phone: 1.800.531.0180 / 1.719.531.5855  
 Fax: 719.531.5690  
 e-mail: vfsales@velcon.com  
 www.velcon.com

**MANUFACTURING PLANTS LOCATED AT:**  
 Colorado Springs, Colorado  
 Sylacauga, Alabama  
 Henryetta, Oklahoma

**OVERSEAS AFFILIATES:**  
 Germany, Spain, Canada & Singapore

**Liquid Filtration  
and Separation  
Specialists**



# Separator Cartridges

## Filter/Separator 2nd Stage Elements

### Features

- Optimum 2nd stage water removal
- Choice of Teflon® Coated Screen, Synthetic or Pleated Paper Media
- Field proven performance
- Largest selection of replacement elements

### General

Separator Cartridges are employed as the second stage in filter/separator vessels. Their sole function is to repel coalesced water drops produced by the first stage cartridges while allowing hydrocarbon fluids to pass through. Water drops settle into the filter/separator sump and are not carried downstream. All particle filtering is done by the first stage coalescer cartridge.

### How Separator Cartridges Work

Flow direction is from outside-to-inside. The top photo insert shows water being repelled by the hydrophobic separator medium on the cartridge's outside surface. Hydrocarbon fluids, on the other hand, easily pass through and exit the separator cartridge. Cartridges with three different types of repelling media are offered:

**Teflon Coated Screen (TCS) Cartridges** are, by far, the most popular type of separator cartridge. With proper cleaning and inspection (see Velcon Form #1242), cost effective TCS elements can be *reused* over many coalescer cartridge changeout cycles. And, TCS cartridges generate considerably less static charge than pleated paper cartridges. These features have made them the preferred choice for aircraft fueling applications.

**Pleated Paper Cartridges** cannot be reused and are replaced at every coalescer cartridge changeout. They are often used with diesel and other fuel oils which may contain materials that adhere to TCS cartridges and cannot be cleaned off.

**Synthetic Media Cartridges** can be cleaned a maximum of two times. They are intended for customers who do not want to take the time to clean separators.

### Separator Cartridge Performance

Maintaining a uniform flow along the length of the cartridge optimizes performance and reduces the number of cartridges required. Flow is controlled by a tube, inside each cartridge, through which the hydrocarbon fluid exits the cartridge and the filter/separator vessel. Two styles of inner tube are offered. See bottom photo.

Cartridges with uniform hole pattern inner tubes are adequate for many applications. However, where optimum flow distribution is required, cartridges with variable hole pattern inner tubes are recommended. When converting older equipment, a lesser number of variable hole pattern cartridges is usually required. Operating costs will therefore be reduced.

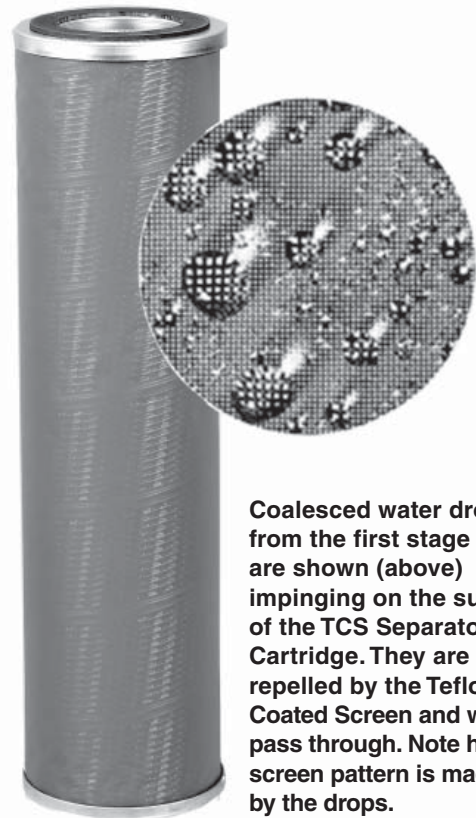

Coalesced water drops from the first stage are shown (above) impinging on the surface of the TCS Separator Cartridge. They are repelled by the Teflon Coated Screen and will not pass through. Note how the screen pattern is magnified by the drops.

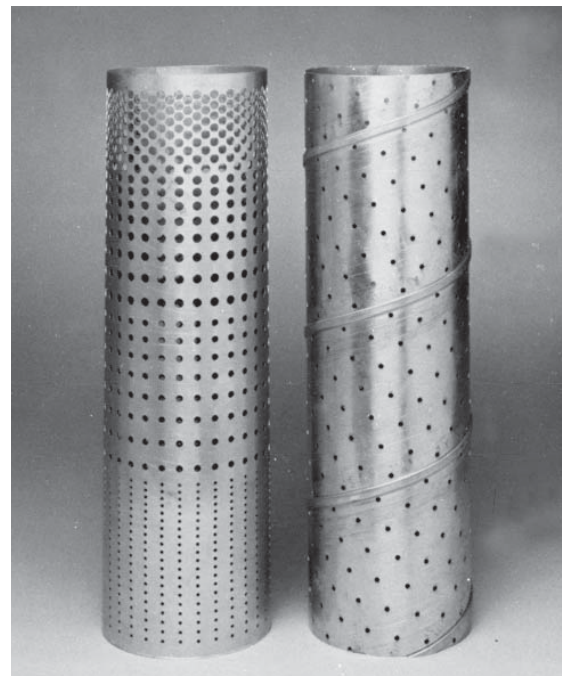

Variable Hole Pattern  
Inner Tube

Uniform Hole Pattern  
Inner Tube

®Teflon is a registered trademark of E.I. du Pont de Nemours & Co., Inc.

# Separator Cartridges

**Model number system.** Refer to box at right and table below. Note that "C" in the code always means a Uniform hole pattern inner tube with TCS media, and "V" means Variable hole pattern with TCS media. Blind caps have a hole for the tie rod.

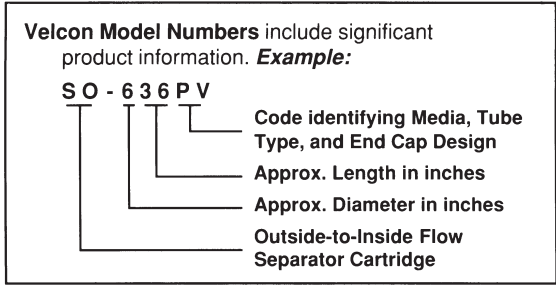

## Cartridge Code Identification

Model Number	Flow Control Hole Pattern	OD	Mounting End ID	Opposite End ID	Media
SO-3xxC	Uniform	3 <sup>1</sup> / <sub>16</sub> "	1 <sup>15</sup> / <sub>16</sub> "	Blind	TCS
SO-3xxV	Variable	3 <sup>1</sup> / <sub>16</sub> "	1 <sup>15</sup> / <sub>16</sub> "	Blind	TCS
SO-4xxC	Uniform	4 <sup>9</sup> / <sub>16</sub> "	3 <sup>1</sup> / <sub>2</sub> "	Blind	TCS
SO-4xxV	Variable	4 <sup>9</sup> / <sub>16</sub> "	3 <sup>1</sup> / <sub>2</sub> "	Blind	TCS
SO-6xxC	Uniform	6"	3 <sup>1</sup> / <sub>2</sub> "	3 <sup>1</sup> / <sub>2</sub> "	TCS
SO-6xxCA	Uniform	6"	3 <sup>1</sup> / <sub>2</sub> "	Blind	TCS
SO-6xxCM	Uniform	6"	4 <sup>1</sup> / <sub>2</sub> "	Blind	TCS
SO-6xxVA (5)	Variable	6"	3 <sup>1</sup> / <sub>2</sub> "	Blind	TCS
SO-6xxV (5)	Variable	6"	4 <sup>1</sup> / <sub>2</sub> "	Blind	TCS
SO-6xxPV (5)	Variable	6"	4 <sup>1</sup> / <sub>8</sub> "	Blind	TCS
SO-6xxPLF3 <sup>(1)</sup>	Uniform	6"	3 <sup>1</sup> / <sub>2</sub> "	3 <sup>1</sup> / <sub>2</sub> "	Pleated Paper
SO-6xxPLBZ <sup>(1)</sup>	Uniform	6"	3 <sup>1</sup> / <sub>2</sub> "	Blind	Pleated Paper
SO-6xxCSN*	Uniform	6"	3 <sup>1</sup> / <sub>2</sub> "	3 <sup>1</sup> / <sub>2</sub> "	Synthetic
SO-6xxCMSN*	Uniform	6"	4 <sup>1</sup> / <sub>2</sub> "	Blind	Synthetic
SO-6xxCPSN*	Uniform	6"	4 <sup>1</sup> / <sub>8</sub> "	Blind	Synthetic
SO-6xxVASN	Variable	6"	3 <sup>1</sup> / <sub>2</sub> "	Blind	Synthetic
SO-6xxVSN	Variable	6"	4 <sup>1</sup> / <sub>2</sub> "	Blind	Synthetic
SO-6xxPVSN	Variable	6"	4 <sup>1</sup> / <sub>8</sub> "	Blind	Synthetic

### Table Notes

SO Series cartridges listed in Code Identification Table at left are the most commonly used types. A variety of other styles are available for special applications. Contact your Velcon distributor for details.

SO-6xxPLF3 pleated separators come in lengths of 11, 14, 16, 29 and 33 inches. SO-6xxPLBZ pleated separators come in lengths of 22, 29, 33 and 44 inches. Frequently, they are installed in stacks of two or three cartridges.

SO-6xxC cartridges are available in these same stackable lengths plus longer lengths. However, single-unit designs are recommended for installation ease and lower cost. Other styles listed in Table are not intended to be stacked.

Velcon variable size hole pattern cartridges should not be replaced with uniform hole pattern cartridges unless appropriate full-scale test data can be supplied showing equivalent performance.

For more information about API/EI 1581 5th Edition qualified separators, please see data sheet 1923.

SO-6xxCSN/CMSN/CPSN separators are intended for customers who want a separator for disposal rather than clean and re-use (can be cleaned a maximum of two times).

1. Please note: The shelf life for pleated paper separators (for example, SO-xxxPLF3 and SO-6xxPLBZ) is one year.

\* U.S. Patent No. 6,068,723 and 6,415,930

## General Specifications

- TCS medium is 200 mesh stainless steel screen coated on both sides with green Teflon. The screen is lockseam folded and fastened with an internal aluminum clip.
- Pleated medium is silicone treated resin impregnated paper with a protective outer aluminum screen jacket.
- Tubes are aluminum.
- End caps are aluminum and/or glass filled nylon.
- Gaskets are Buna-N.
- pH range is 5 to 9.
- Maximum operating temperature is 200°F.

Velcon products are sold and serviced by a world-wide representative network. To order, contact Headquarters or your **LOCAL REPRESENTATIVE:**

**COMPANY HEADQUARTERS:**  
 Velcon Filters, Inc.  
 1210 Garden of the Gods Road  
 Colorado Springs, CO 80907-3410  
 Phone: 1.800.531.0180 / 1.719.531.5855  
 Fax: 719.531.5690  
 e-mail: vfsales@velcon.com  
 www.velcon.com

**MANUFACTURING PLANTS LOCATED AT:**  
 Colorado Springs, Colorado  
 Sylacauga, Alabama  
 Henryetta, Oklahoma

**OVERSEAS AFFILIATES:**  
 Frankfurt/M., Germany & Singapore

**Liquid Filtration  
 and Separation  
 Specialists**

## High Efficiency, Long Life Cartridges for Industrial Fluids



FO-424PLxx



FO-718PLxx



FO-614PLFxx



FO-512PLxx



FO-644PLFxxTB

- **Large Surface Area** – Allows high flow rate with low initial pressure drop and maximum contaminant holding capacity.
- **Resin Impregnated Media** – Maintains strength, resists effects of water and heat.
- **75 psi Collapse Strength** – Heavy gauge carbon steel endcaps and center tube give safety margin against pressure surges.
- **Coated Steel Components** – Resist corrosion from most industrial fluids.
- **Corrugated Media** – Prevents pleat pinch-off, assuring all filtration media is utilized.
- **Buna-N Gaskets** – The best general gasket material available assures positive seal in most fluids.
- **Thermoset Bonding Material** – Durable endcap-to-media bond prevents internal bypassing.
- **Threaded base filter cartridges** – Available for easier installation.

### APPLICATIONS

Velcon Pleated Media Cartridges are suitable for a broad range of polar and non-polar fluids. Recommended for applications where the contaminant is granular (non-colloidal), allowing maximum utilization of the high surface area.

### Suitable for:

All Hydrocarbon Fuels	Cutting Oils	Insulating Oils	Glycols	Toluol	Naphtha
Diesel Fuel	Lube Oils	Hydraulic Oils	Water Emulsion	Coolants	
Biodiesel Fuel	Synthetic Oils	Ethyl Alcohol	Degreasing Fluids		

### SPECIFICATIONS

75 psi Collapse strength	250°F Maximum operating temperature
5 - 9 Operating pH range	Recommended changeout differential pressure - 25 psid
Micron ratings from 1/4 to 75	Multi-pass (Beta Ratio) data available on request
98%+ Nominal filtration efficiency	

For information about Flow Ratings with various viscosity fluids, refer to Form #1532

**Photos - please note:** The outer wrap of a cartridge can be either nylon jacket, beaming paper, or PVC-coated screen wrap. Actual cartridges may not look exactly like those shown in photo. In the part numbers above, "xx" represents micron rating of the cartridge.

## CARTRIDGE INFORMATION

The following table lists a few of the broad range of available Velcon cartridges. Your local Velcon Representative can provide more complete information.

Dimensions	Model	Nominal Micron Rating	Protective Outer Wrap
4" x 12¼" x 1¾" ID	FO-412PL2	2	No
	FO-412PL5	5	No
4" x 18" x 1¾" ID	FO-418PL5	5	No
	FO-418PL15	15	No
For VF-61 Housing	FO-512PL1/2	½	No
	FO-512PL05	5	No
	FO-512PL25	25	No
6" x 14½" x 3½" ID	FO-614PLF½	½	No
	FO-614PLF1	1	No
	FO-614PLF2	2	No
	FO-614PLF5	5	No
	FO-614PLF5M	5	Yes
	FO-614PLF10	10	No
	FO-614PLF15	15	No
	FO-614PLF15M	15	Yes
	FO-614PLF25	25	No
	FO-614PLF25M	25	Yes
	FO-614PLF75	75	No
6" x 29" x 3½" ID	FO-629PLF1/4	¼	Yes
	FO-629PLF1/2	½	Yes
	FO-629PLF1	1	Yes
	FO-629PLF2	2	Yes
	FO-629PLF5	5	Yes
	FO-629PLF10	10	Yes
	FO-629PLF20	20	Yes
	FO-629PLF25	25	Yes
6" x 29" Threaded Base	FO-629PLF1/2TB	½	Yes
	FO-629PLF1TB	1	Yes
	FO-629PLF2TB	2	Yes
	FO-629PLF5TB	5	Yes
	FO-629PLF25TB	25	Yes

Dimensions	Model	Nominal Micron Rating	Protective Outer Wrap
6" x 44" x 3½" ID	FO-644PLF1/2	½	No
	FO-644PLF1M	1	Yes
	FO-644PLF2M	2	Yes
	FO-644PLF5M	5	Yes
	FO-644PLF10M	10	Yes
	FO-644PLF15M	15	Yes
	FO-644PLF25M	25	Yes
6" x 44" Threaded Base	FO-644PLF1/4TB	¼	Yes
	FO-644PLF1/2TB	½	Yes
	FO-644PLF1TB	1	Yes
	FO-644PLF2TB	2	Yes
	FO-644PLF5TB	5	Yes
	FO-644PLF10TB	10	Yes
	FO-644PLF25TB	25	Yes
6" x 56" x 3½" ID	FO-656PLF1M	1	Yes
6" x 56" Threaded Base	FO-656PLF1/2TB	½	Yes
	FO-656PLF1TB	1	Yes
	FO-656PLF2TB	2	Yes
	FO-656PLF5TB	5	Yes
	FO-656PLF25TB	25	Yes
6¼" x 18" x 2 <sup>9</sup> / <sub>16</sub> " ID	FO-718PLP3	0.3	No
	FO-718PL1/2	½	No
	FO-718PL01	1	Yes
	FO-718PL02	2	Yes
	FO-718PL05	5	Yes
	FO-718PL10	10	Yes
	FO-718PL15	15	Yes
	FO-718PL25	25	Yes
	FO-718PL50	50	Yes
	6¼" x 36" x 2 <sup>9</sup> / <sub>16</sub> " ID	FO-736PLP3	0.3
FO-736PL1/2		½	No
FO-736PL05		5	Yes
FO-736PL15		15	Yes
8" x 22 <sup>1</sup> / <sub>8</sub> " x 2" ID	FO-822PLP3	0.3	No
	FO-822PL1/2	½	No
	FO-822PL05	5	No
8" x 29½" x 2" ID	FO-829PL05	5	No



Velcon products are sold and serviced by a world-wide representative network. To order, contact Headquarters or your LOCAL REPRESENTATIVE:

**COMPANY HEADQUARTERS:**  
Velcon Filters, LLC  
1210 Garden of the Gods Road  
Colorado Springs, CO 80907-3410  
Phone: 1.800.531.0180 / 1.719.531.5855  
Fax: 719.531.5690  
e-mail: vfsales@velcon.com  
www.velcon.com

**MANUFACTURING PLANTS LOCATED AT:**  
Colorado Springs, Colorado  
Sylacauga, Alabama  
Henryetta, Oklahoma

**OFFICES AND AFFILIATES IN:**  
Canada, Germany, Singapore & Spain



**Liquid Filtration  
and Separation  
Specialists**

## Remove Water and Dirt from Oils, Fuels and Gases

- Removes free and emulsified water to less than 2 ppm
- Differential pressure increase alerts operator to change cartridges
- Effectively filters silt and other particulates
- No media migration or “linting”
- Easy to install and remove
- Does not affect oil additives
- Fits standard filter housings

**Aquacon<sup>®</sup>** Cartridges have a patented\* construction for removing dirt and water from hydrocarbon and other oils as well as gases. The outer media layer filters out silt, rust and other particulate contaminants. The inner layers absorb water and chemically bond it so that no water will release downstream.

When the **Aquacon** Cartridge reaches its water holding limit, the media swells shut and the differential pressure rapidly increases. This signals the operator that the cartridge must be changed.

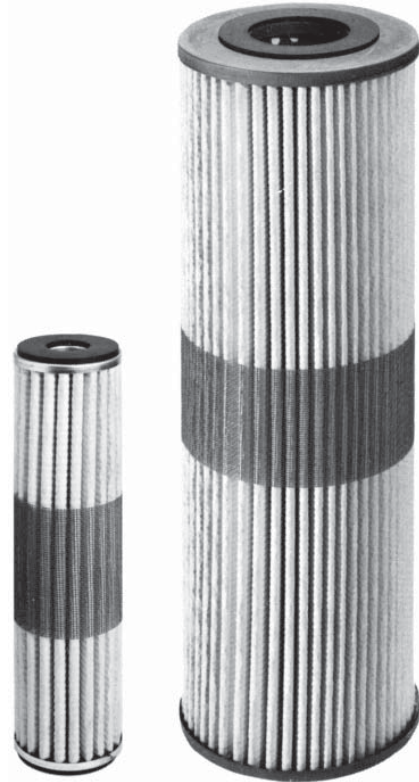

### APPLICATIONS

Gasoline	Hydraulic Oil
Kerosene	Turbine Lube Oil
Diesel Fuel	Quench Oil
Insulating Oil	Synthetic Oil
Biodiesel	Phosphate Ester Oil

### TECHNICAL INFORMATION

1. Maximum operating temperature is 250°F.
2. **Aquacon** Cartridges will shut off flow when loaded with water or dirt. Appropriate precautions should be taken in critical applications where oil flow must be maintained.
3. With some lube and hydraulic oils all of the water may not be removed in one pass, and extra passes will be required for total removal.
4. Water capacity for the AC-718 cartridges ranges from 2 to 4 quarts.

**WARNING:** Absorbent-type monitor cartridges will not remove water from fuel containing alcohol-blending agents (commonly called gasohol). For removal of solids, please use Velcon particle removal filters specifically made for gasohol. Consult your Velcon representative.

## CARTRIDGE INFORMATION

New types of **Aquacon**® Cartridges are being introduced continually. Contact your local Velcon Representative for up-to-date information.

Model Number	Micrometer Reading		I.D. Inches	O.D. Inches	Length Inches	Collapse Pressure, psi	Interchange Information
	Normal	Beta <sub>x</sub> = 75					
AC-21005 <sup>(1)</sup>	5	40	1	2 5/8	9 3/4	75	Fits Velcon VF-31 Housings
AC-5121/2E <sup>(2)</sup>	0.5	3	1 7/8	5 5/8	12 1/8	75	Fits Velcon VF-61 Housings
AC-51205	5	40	1 7/8	5 5/8	12 1/8	75	
AC-61405	5	40	3 1/2	6	14 1/2	100	Interchanges with Velcon FO-614PLF, FO-629PLF, and FO-644PLF Series Cartridges
AC-62905	5	40	3 1/2	6	29 1/2	100	
AC-64405	5	40	3 1/2	6	44	100	
AC-718P3 <sup>(2)</sup>	0.3	2	2 9/16	6 1/4	18	75	Fits Velcon industrial housings and portable filters, interchangeable with Velcon FO-718PL and FO-736PL Series Cartridges
AC-718P4D	0.4	2.5	2 9/16	6 1/4	18	75	
AC-7181/2 <sup>(2)</sup>	0.5	3	2 9/16	6 1/4	18	75	
AC-71801	1	6	2 9/16	6 1/4	18	75	
AC-71805	5	40	2 9/16	6 1/4	18	75	
AC-7361/2 <sup>(2)</sup>	0.5	3	2 9/16	6 1/4	36	75	
AC-73601	1	6	2 9/16	6 1/4	36	75	
AC-73605	5	40	2 9/16	6 1/4	36	75	

**Notes:** (1) The AC-21005 will fit into many existing housings that take “string-wound” cartridges. Check to confirm that the 9 3/4” length will seat properly in the housing.

(2) The AC-5121/2E, AC-718P3, AC-7181/2 and AC-7361/2 are increased surface area/reduced water capacity cartridges specifically designed for circuit breaker oil.

## TYPICAL **Aquacon**® CARTRIDGE CONSTRUCTION

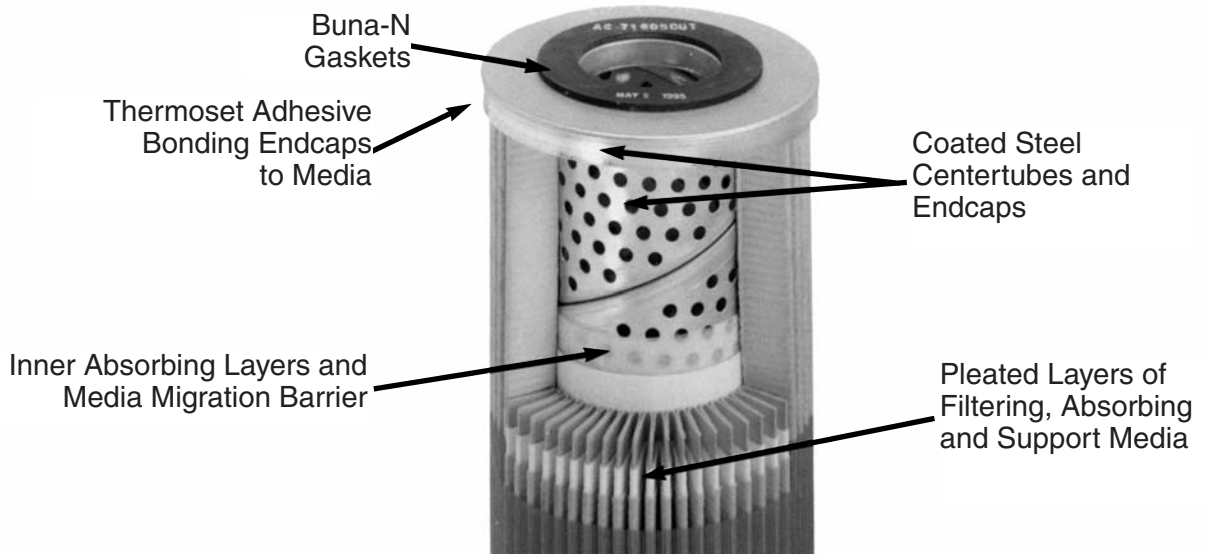

Velcon products are sold and serviced by a world-wide representative network. To order, contact Headquarters or your **LOCAL REPRESENTATIVE**:

**COMPANY HEADQUARTERS:**  
 Velcon Filters, LLC  
 1210 Garden of the Gods Road  
 Colorado Springs, CO 80907-3410  
 Phone: 1.800.531.0180 / 1.719.531.5855  
 Fax: 719.531.5690  
 e-mail: vfsales@velcon.com  
 www.velcon.com

**MANUFACTURING PLANTS LOCATED AT:**  
 Colorado Springs, Colorado  
 Sylacauga, Alabama  
 Henryetta, Oklahoma

**OFFICES & AFFILIATES IN:**  
 Canada, Germany, Singapore & Spain



**Liquid Filtration  
 and Separation  
 Specialists**



# ACO Aquacon® Aviation Fuel Filter Cartridges

## Remove Water and Dirt from Jet Fuel and Avgas Outside-to-In Flow Cartridges

- Free and emulsified water removal to less than 5 ppm
- 1/2 micrometer particle removal
- Provides protection against “slugs” of water
- Pressure increase signals need for cartridge change
- Use with existing filter housings

### DESCRIPTION

Patented **Aquacon**® Filter Cartridges have a unique high-capacity inner filter medium which removes all free and emulsified water from hydrocarbon fuels down to less than 5 ppm in the effluent. Absorbed water is chemically locked into this medium.

When a cartridge reaches its water holding capacity, its accordion pleats swell and cause an increase in the differential pressure which signals the operator to change the cartridge.

Solid contaminants are removed by the cartridge’s two particulate filter media layers. The pleated accordion style design provides a large surface area for maximum dirt holding capacity. Models are offered for particle filtration down to 1/2 micrometer size with 98% plus efficiency. Performance is not affected by the presence of common surface active agents.

Compact **Aquacon**® Cartridges are quick and easy to install. Models are available to fit most existing standard housings. Refer to Cartridge Selection Table on reverse side.

Use Form 1846 for cartridge changeout recommendations at flowrates less than rated flow.



ACO-60901L



ACO-51201L

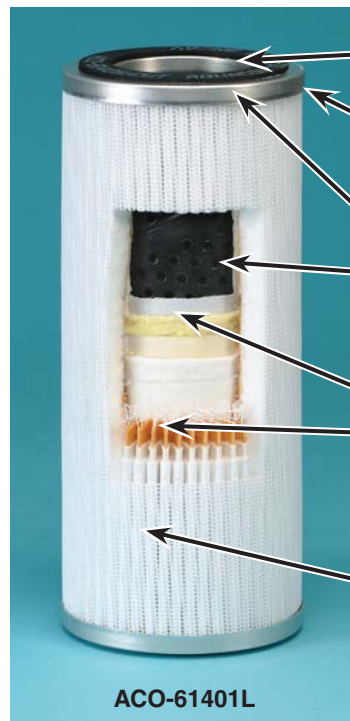

ACO-61401L

- Buna-N Gaskets
- Thermoset Adhesive Bonding of Endcaps to Media
- Steel or Aluminum Centertubes and Endcaps
- Inner Absorbing Layer and Media Migration Barrier
- Layers of Filtering, Absorbing, and Support Media

Typical Aquacon Cartridge Construction

## CARTRIDGE SELECTION TABLE

Model Number	Micron Ratings	Inside Diameter (Inches)	Outside Diameter (Inches)	Length (Inches)	Collapse Pressure (psi)	Maximum Flow Rate (USGPM)	Interchange Information
ACO-21001L	0.5	1 1/32	2 5/8	9 3/4	60	15	Fits VF-31E Housing
ACO-31001L	0.5	1 5/16	3	9 3/4	75	20	Fits Purolator Vessel PR-172-3
ACO-40501SPL	0.5	1-12NF	3 3/4	5 1/2	60	10	Use with head SPH-2
ACO-40801L	0.5	1 3/4	4	8	100	13	Rellumit Replacement
ACO-40901SPL	0.5	1 3/8 -12NF	3 3/4	8 1/2	60	15	Use with head SPH-3
ACO-41201L	0.5	1 3/4	4	12 1/4	100	20	Replaces Facet C-707; Purolator Vessel PAG-50
ACO-41601L	0.5	1 3/4	4	15 13/16	100	27	Rellumit Replacement
ACO-41801L	0.5	1 3/4	4	18	100	30	Replaces Facet C-706 and Keene BP-419, BP-518
ACO-41901L	0.5	1 3/4	4	19 7/8	175	32	Rellumit Replacement
ACO-51201L	0.5	1 7/8	5 5/8	12 1/4	75	50	Fits VF-61 Housing
ACO-512P3L	0.3	1 7/8	5 5/8	12 1/4	75	50	Fits VF-61 Housing
ACO-60801L	0.5	3 1/2	6	8 1/4	100	30	Omeco 6" x 8" Replacement
ACO-60901L	0.5	1 1/2	6	9 11/16	100	36	Fits Fram/Facet VFCS-21 (Element CC-21-7); VF-609
ACO-609P3L	0.3	1 1/2	6	9 9/16	100	36	Fits Fram/Facet VFCS-21 (Element CC-21-7); VF-609
ACO-61201L	0.5	1 1/2	6	13 3/4	100	48	Fits Fram/Facet VFCS-22 (Element CC-22-7)
ACO-61401L	0.5	3 1/2	6	14 1/2	175	58	Qualified to EI 1583
ACO-62201LTB	0.5	3 1/2	6	22	175	88	Qualified to EI 1583
ACO-62901L	0.5	3 1/2	6	28 3/4	175	115	Qualified to EI 1583
ACO-63301L	0.5	3 1/2	6	33 1/4	175	133	Qualified to EI 1583
ACO-64401L	0.5	3 1/2	6	43 1/4	175	173	Qualified to EI 1583
ACO-64401LTB	0.5	3 1/2	6	44	175	176	Qualified to EI 1583
ACO-71801L	0.5	2 1/2	6 1/4	18	75	65	Fits VF-71E Housing

### TECHNICAL INFORMATION

1. Maximum operating temperature is 160°F
2. Micron ratings are nominal at 98%+ efficiency
3. **Aquacon**® Cartridges can significantly reduce flow when loaded with water or dirt. Appropriate precautions should be taken in applications where fuel flow must be maintained or where surge conditions can occur.

4. Replace the cartridge if the differential pressure exceeds 25 psid. For service life information, please refer to Operating Procedure # 1839 or consult your company fuel handling procedures.
5. Typical water holding capacity for ACO-61401L is 700 ml

**NOTE:** 1/2 micron rated **Aquacon**® Cartridges are recommended for use with jet fuel and avgas. Effluent fuel quality meets requirements for EI 1583.

**CAUTION:** DO NOT USE WITH PRE-MIXED FUELS CONTAINING ANTI-ICING ADDITIVES



Velcon products are sold and serviced by a world-wide representative network. To order, contact Headquarters or your LOCAL REPRESENTATIVE:

**COMPANY HEADQUARTERS:**  
 Velcon Filters, Inc.  
 1210 Garden of the Gods Road  
 Colorado Springs, CO 80907-3410  
 Phone: 1.800.531.0180 / 1.719.531.5855  
 Fax: 719.531.5690  
 e-mail: vfsales@velcon.com  
 www.velcon.com

**MANUFACTURING PLANTS LOCATED AT:**  
 Colorado Springs, Colorado  
 Sylacauga, Alabama  
 Henryetta, Oklahoma

**OVERSEAS AFFILIATES:**  
 Frankfurt/M., Germany & Singapore

**Liquid Filtration  
 and Separation  
 Specialists**



# CDF<sup>®</sup> Fuel Monitor Cartridges N Series

## Field Proven: CDF Replacement Cartridges Assure Clean Dry Fuel Delivery

### FEATURES

CDF-N SERIES are qualified to IP 1583, Fourth Edition, a specification for Aviation Fuel Filter Monitors.

#### IMPROVED SALT WATER PERFORMANCE

CONDUCTIVE END CAPS and adhesive for reduction of static charge within the vessel.

O-RING SEAL minimizes the possibility of bypassing contaminated fuel at differential pressures up to 175 psi.

RUGGED CONSTRUCTION collapse strength exceeds 175 psi differential pressure.

### DESCRIPTION

The Velcon CDF<sup>®</sup> N Series cartridges are designed to provide superior performance and reliability in standard fuel monitor housings through a unique, patented combination of media that absorbs water, filters solids that may be present in the fuel, and provides for reduced static charge.

The cartridge has injection molded endcaps that are bonded to the media and an O-ring seal on the outlet end. This minimizes the possibilities of bypassing contaminated fuel or transmission of water downstream at low flow rates.

As the cartridge removes water and/or dirt from the influent fuel there will be an increase in the pressure differential along with a decrease in flow rate. These changes are the result of flow restriction caused by dirt filtration or water absorption in the media. The rate of these changes depends on the quantity of water or dirt contaminants present.



**\*\*\*CAUTION\*\*\***  
**DO NOT USE WITH PRE-MIXED FUEL  
CONTAINING ANTI-ICING ADDITIVES.**

## IP Specification 1583 Fourth Edition Information

Our new CDF®-2xxN Series Cartridges incorporate features that result in increased electrical conductivity to quickly dissipate electrostatic charge across the cartridge. This is in response to the new requirement in the specification to reduce static charge within the filter monitor.

Another addition to the specification is an optional test to determine the performance of the cartridge in a salt water environment. The CDF® N Series successfully passed the following tests:

1. ¾ % Sodium Chloride full flow slug test
2. ¾ % Sodium Chloride 50 ppm test

## ORDERING INFORMATION

- Specify Velcon Model Number from table below.  
CDF Cartridges are packaged 20 per carton.

## CARTRIDGE SELECTION TABLE

Cartridge Flow Rate USGPM	Velcon Model Number	Overall Length	Replacements for:		
			Facet Model Number	Racor Model Number	Faudi Model Number
5	CDF-205N	5 <sup>13</sup> / <sub>16</sub> "	FG-205 (-3 or -4) GNG-205	RMO-205-4-E —	M.2-134 (/4 or /E)
10	CDF-210N	10 <sup>13</sup> / <sub>16</sub> "	FG-210 (-3 or -4) GNG-210	FMI-10203 FM-10202 RMO-210-4-E	M.2-261 (/4 or /E)
15	CDF-215N	15 <sup>13</sup> / <sub>16</sub> "	FG-215 (-3 or -4) GNG-215	FMI-15203 FM-15202 RMO-215-4-E	M.2-387 (/4 or /E)
20	CDF-220N	20 <sup>13</sup> / <sub>16</sub> "	FG-220 (-3 or -4) GNG-220	FMI-20203 FM-20202 RMO-220-4-E	M.2-515 (/4 or /E)
25	CDF-225N	25 <sup>13</sup> / <sub>16</sub> "	FG-225 (-3 or -4) GNG-225	FMI-25203 FM-25202 RMO-225-4-E	M.2-642 (/4 or /E)
30	CDF-230N	30 <sup>13</sup> / <sub>16</sub> "	FG-230 (-3 or -4) GNG-230	FMI-30203 FM-30202 RMO-230-4-E	M.2-770 (/4 or /E)

## SPECIFICATIONS AND TECHNICAL INFORMATION CDF® N SERIES

- 175 psid (12 bar) collapse strength
- 0.5 micron rating
- 160°F maximum operating temperature
- Recommended changeout differential pressure = 25 psid
- For service life information, please refer to Operating Procedures # 1839 or consult your company fuel handling procedures.

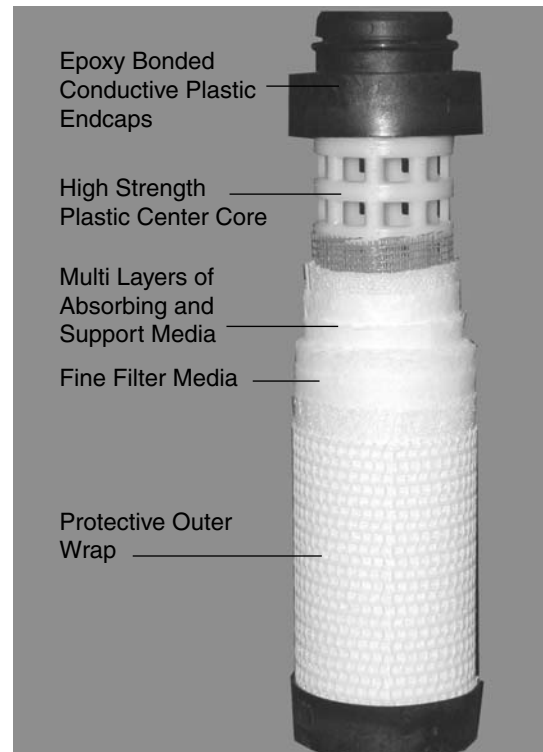



Velcon products are sold and serviced by a world-wide representative network. To order, contact Headquarters or your **LOCAL REPRESENTATIVE**:

**COMPANY HEADQUARTERS:**  
 Velcon Filters, Inc.  
 1210 Garden of the Gods Road  
 Colorado Springs, CO 80907-3410  
 Phone: 1.800.531.0180 / 1.719.531.5855  
 Fax: 719.531.5690  
 e-mail: vfsales@velcon.com  
 www.velcon.com

**MANUFACTURING PLANTS LOCATED AT:**  
 Colorado Springs, Colorado  
 Sylacauga, Alabama

**OVERSEAS AFFILIATES:**  
 Frankfurt/M., Germany & Singapore

**Liquid Filtration  
 and Separation  
 Specialists**

## High Performance Replacements for Pleated Paper Cartridges Upgrade Your Oil Filtration Using Existing Housings

### FEATURES

- Superior Filtration Efficiency
- Long-Life Durability
- Low Pressure Drop
- High Flow Rates
- No New Hardware Required

### DESCRIPTION

FOS Series synthetic media cartridges provide excellent filtration performance for a wide variety of industrial applications. They excel in applications where water or chemicals cause softening or degradation of conventional resin impregnated cellulose (pleated paper) filter media. Due to the finer synthetic fibers used, FOS cartridges have a low pressure drop. Replacing an equivalent size paper filter will, in many cases, result in improved filtration efficiency, higher flow rates, longer service life, and significant cost savings.

### APPLICATIONS

- Turbine Lube Oil
- Water Soluble Oils
- Paper Machine Lube Oil
- Synthetic Base Oils
- Compressor Lube Oil

A selection of FOS Series cartridges, suitable for a wide variety of applications, is offered:

FOS-512PL25 and FOS-718PL25 have a nominal 25 micron filtration rating. They are especially effective with cutting oils, and in some cases have had five times the life of equivalent size paper filters.

FOS-618PL05 and FOS-636PL05 have a nominal 5 micron filtration rating. They provide improved filtration for synthetic-based compressor lube oil applications.

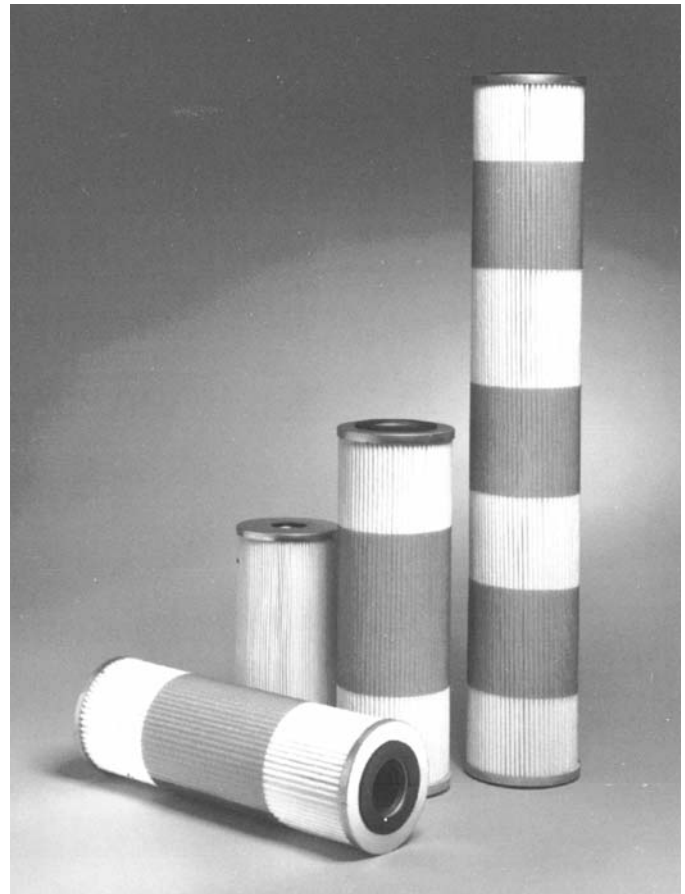

FOS-618PL1/2    FOS-512PL25    FOS-618PL1/2  
FOS-636PLP8 lying on side

The 0.8 micron rated FOS-618PLP8 and FOS-636PLP8 are excellent "fine particle removal" filters and frequently are installed in existing lube oil filtration systems to upgrade system cleanliness.

FOS-618PL1/2 and FOS-636PL1/2 have a nominal 0.5 micron filtration rating. These models provide efficient removal of extremely fine particles without sacrificing cartridge life. They are used where tough ISO code oil cleanliness is needed.

## GENERAL SPECIFICATIONS

- Collapse strength 75 psi
- Max. Operating temperature 250°F
- pH operating range 3 - 9
- Recommended change-out at 25 psid differential pressure or after one year, whichever occurs first
- Buna-N gasket material
- Filter media are glass micro-fibers backed by spun-bonded polyester and metal screen. Twenty-five micron designs are spun-bonded polyester only.
- Metal components are aluminiumized steel. FOS-512PL25 end caps are aluminum.
- End cap bonding material is epoxy. Twenty-five micron designs use plastisol.

## CARTRIDGE SELECTION TABLE

Cartridge Model	O.D. (Inches)	I.D. (Inches)	Length (Inches)	Surface Area (In. <sup>2</sup> )	Nominal <sup>(1)</sup> Rating (Microns)	Beta <sub>5</sub>	Size <sup>(2)</sup> where Beta=75	ACFTD Capacity (GMS)
FOS-512PL25	5 <sup>5</sup> / <sub>8</sub>	n.a.	12 <sup>1</sup> / <sub>4</sub>	2390	25	n.a.	60	210
FOS-718PL25	6 <sup>1</sup> / <sub>4</sub>	2 <sup>9</sup> / <sub>16</sub>	18	3970	25	n.a.	60	360
FOS-618PL05	6	2 <sup>9</sup> / <sub>16</sub>	18	2000	5	3.5	37	172
FOS-618PLP8	6	2 <sup>9</sup> / <sub>16</sub>	18	2000	0.8	90	8	87
FOS-618PL1/2	6	2 <sup>9</sup> / <sub>16</sub>	18	2000	1/2	250	4	71
FOS-636PL05	6	2 <sup>9</sup> / <sub>16</sub>	36	4160	5	3.5	37	358
FOS-636PLP8	6	2 <sup>9</sup> / <sub>16</sub>	36	4160	0.8	90	8	180
FOS-636PL1/2	6	2 <sup>9</sup> / <sub>16</sub>	36	4160	1/2	250	4	148

**NOTES:** <sup>(1)</sup>Nominal gravimetric filter micron rating.

<sup>(2)</sup>Particle size (microns) where Beta equals 75. Often referred to as the "absolute" rating of the cartridge.



Velcon products are sold and serviced by a world-wide representative network. To order, contact Headquarters or your **LOCAL REPRESENTATIVE:**

**COMPANY HEADQUARTERS:**  
 Velcon Filters, Inc.  
 1210 Garden of the Gods Road  
 Colorado Springs, CO 80907-3410  
 Phone: 1.800.531.0180 / 1.719.531.5855  
 Fax: 719.531.5690  
 e-mail: vfsales@velcon.com  
 www.velcon.com

**MANUFACTURING PLANTS LOCATED AT:**  
 Colorado Springs, Colorado  
 Sylacauga, Alabama

**OVERSEAS AFFILIATES:**  
 Frankfurt/M., Germany & Singapore

**Liquid Filtration  
 and Separation  
 Specialists**

# Velcon®

1210 Garden of the Gods Rd., Colorado Springs, CO 80907  
Phone: (719) 531-5855 FAX: (719) 531-5690  
Toll-free: (800) 531-0180  
e-mail: vfsales@velcon.com / web site: www.velcon.com

## IMPORTANT OPERATING PROCEDURES

### Operation of Vessels Containing Water Absorbing Cartridges (ACO/ACI/CDF®) for Aviation Fuel

**NOTE: If pump discharge pressure can exceed 25 psi, do not use this cartridge unless pressure gauges are installed to measure the differential pressure. For ALL systems, differential pressure gauges are strongly recommended, along with daily monitoring of dP. If the gauges cannot be observed easily during flow, an electronic monitoring method, with flow shutdown capability, is recommended.**

**NOTE: Always ensure that the vessel and drain plug are properly grounded. If the *Aquacon*® cartridge (ACO-xxxx) is used in a VF-31E, VF-61, VF-61E, or VF-609 or similar sized housings, please refer to the instructions for the housings in which cartridges are installed for more information.**

Contact Velcon for more information.

#### Recommended procedures\* to follow with water absorbing cartridges in a vessel:

1. Reinforce quality control checks and diligently conduct water removal procedures at all locations in the fuel distribution system. This includes daily draining of all sumps, low points, and dead legs in the piping system.
2. Monitor differential pressure daily - if operating at reduced flow, record differential pressure and flow rate and calculate normalized differential pressure. (See page 2). *Change ACO, ACI, & CDF® cartridges when normalized differential pressure reaches 25 psid\*\*. Replace all cartridges if the normalized differential pressure has dropped 5 psid below the previous reading.*
3. Sample fuel and check for free water content using the Velcon Hydrokit® or other chemical method in accordance with your company's fuel handling procedures. Replace cartridges if the water content exceeds your company guidelines.
4. In converted filter/separator vessels where the deckplate or manifold strength does not meet the 15 bar (220 psi) strength required by the EI Monitor Spec. 1583, a differential pressure limiting device, set from 25-30 psid, should be installed across the vessel.
5. Have a spare set of water absorbing cartridges on hand, or available at a nearby Velcon Distributor, for the unexpected plug-up.
6. If fueling unit is operating consistently below 50% of rated flow then periodically check fueling unit at test stand and check DP at flow rate of 50% or higher and confirm corrected DP.
7. After changing cartridges circulate flow through vessel for at least 3 minutes, use millipores to check for fibers and also check hose end strainers.

(Continued, over →)

**\*Please also check with your company's fuel handling guidelines and operating procedures.**

**\*\*ATA 103 compliance now requires 15 psid normalized differential pressure changeout.**

8. As the cartridges begin to restrict the flow due to a water slug, ALL upstream and downstream piping should be checked and purged before resuming operations with a new set of cartridges. Any aircraft involved in fueling when the flow through a cartridge is restricted, should also be checked for the possibility of water reaching the aircraft. Check the tank to determine where the excess water came from, and purge the tank of any water before resuming operation.
9. Cartridges should not be dried and re-used. When water saturated media is dried, it may shrink and crack, leading to possible internal bypass.

**SERVICE LIFE**

Service life for all water absorbing cartridges, including two (2), five (5) and six (6) inch diameter cartridges, should be one (1) year, unless stated otherwise by your company's fuel handling procedures.

**\*\*\*\*\*CAUTION\*\*\*\*\***  
 DO NOT USE WATER ABSORBING CARTRIDGES WITH PRE-MIXED JET FUEL CONTAINING ANTI-ICING ADDITIVES

**WARNING: Absorbent-type monitor cartridges will NOT remove water from fuel containing alcohol-blending agents (commonly called gasohol). For removal of solids, please use Velcon particle removal filters specifically made for gasohol. Consult your Velcon representative.**

For technical support, contact Velcon or your authorized Velcon distributor.  
 See also [www.velcon.com](http://www.velcon.com)

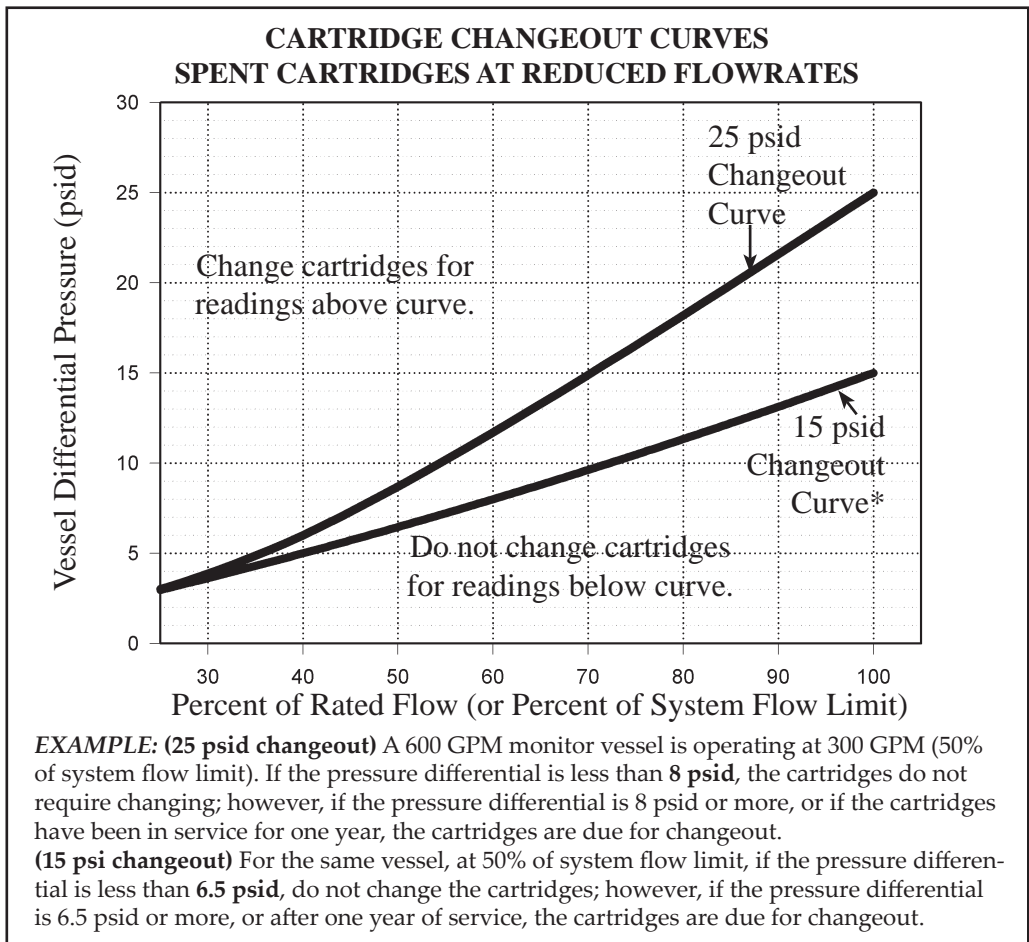

Decal #1846 - Cartridge Changeout Curve for cartridges with 25 psid changeout requirements  
 \*Decal #1979 - Cartridge Changeout Curve for cartridges with 15 psid changeout requirement (per ATA 103)