



Filter/Separator

VV-1033

Compact Design

Simplified Maintenance

DESCRIPTION

The compact VV-1033 is suitable for use in many applications. This filter/separator can be used on mobile refueling equipment and in fueling cabinets. The unit is designed for easy maintenance with a one-piece threaded base coalescer inside a reusable Teflon® coated screen separator canister.

APPLICATIONS

- Jet Fuel
- Avgas
- Motor Gasoline
- Diesel Fuel

STANDARD FEATURES

- Carbon Steel Construction
- 150 psi design pressure
- Epoxy coated interior, primed exterior
- 2" NPT female inlet/outlet
- 3/4" NPT drain connection
- 1/4" NPT vent connection

OPTIONAL FEATURES

- Air Eliminator
- Drain Valve
- Connector for Gems Level Switch
- Leg Assembly with adjustable height
- ASME Code Stamp
- Can be retrofitted with the ACI-63301LTB or ACI-63801LTB **Aquacon**® cartridge

HOUSING INFORMATION

- Vessel Weight: 180 lbs
- Shipping Weight: 230 lbs
- Volume: 14 US gals
- Lid Gasket (Buna-N): G-1110



VV-1033 with optional leg assembly

® Teflon is a registered trademark of E.I. du Pont de Nemours & Co., Inc.

Filter/Separator VV-1033

CARTRIDGE INFORMATION

Product	Flow Rate (USGPM)	Coalescer Element (1 required per vessel)	Separator Element* (1 required per vessel)
Jet Fuel	100	I-63387TB	SI-818
Avgas	130	I-63383TB	SI-818
Motor Gasoline	130	I-63383TB	SI-818
Diesel Fuel	50	I-6384TB	SI-836

* Separator Replacement Gasket: G-1134

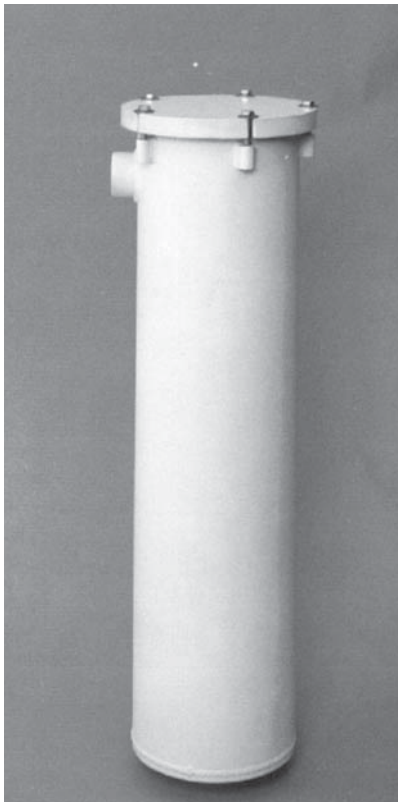

Standard VV-1033 Filter/Separator

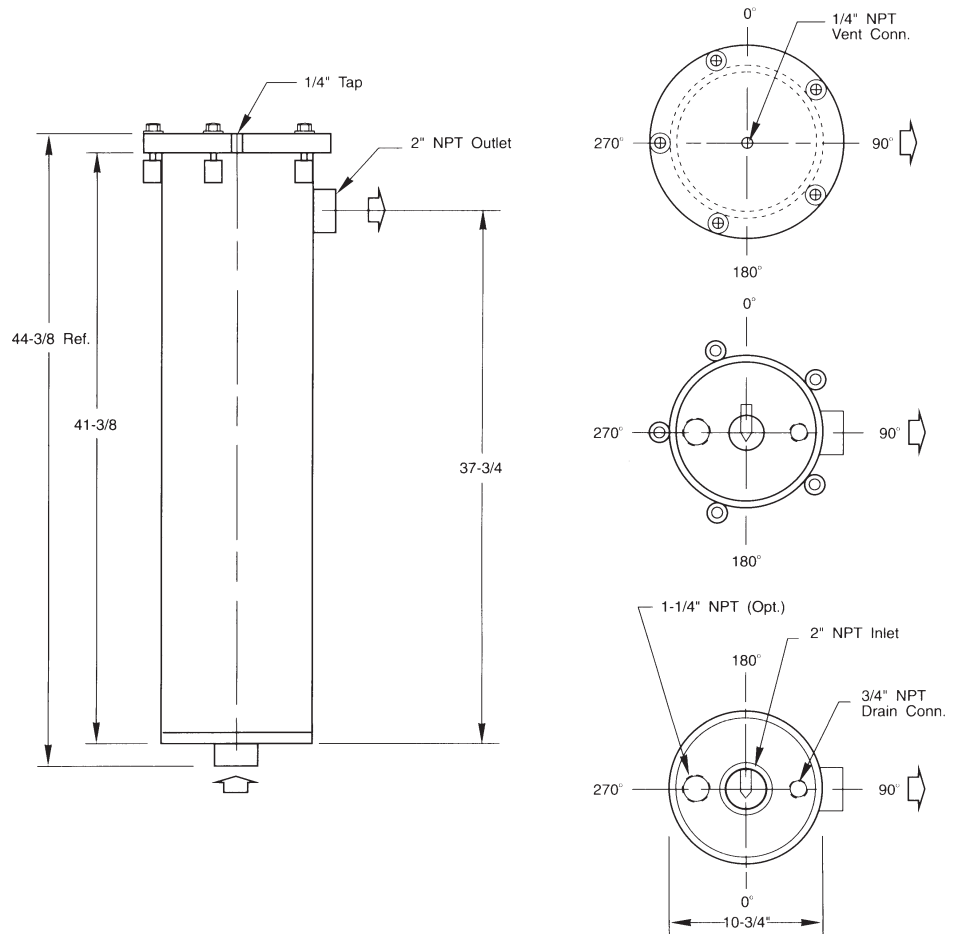

Dimensions Shown Are For Estimating Purposes Only. For Exact Dimensional Detail, Obtain Certified Copy of Vessel Drawing.



Velcon products are sold and serviced by a world-wide representative network. To order, contact Headquarters or your LOCAL REPRESENTATIVE:

COMPANY HEADQUARTERS:
 Velcon Filters, Inc.
 1210 Garden of the Gods Road
 Colorado Springs, CO 80907-3410
 Phone: 1.800.531.0180 / 1.719.531.5855
 Fax: 719.531.5690
 e-mail: vfsales@velcon.com
 www.velcon.com

MANUFACTURING PLANTS LOCATED AT:
 Colorado Springs, Colorado
 Sylacauga, Alabama
 Henryetta, Oklahoma

OVERSEAS AFFILIATES:
 Frankfurt/M., Germany & Singapore

**Liquid Filtration
 and Separation
 Specialists**